

CONTENTS

www.autolinearmotion.com



2	CONTENTS
3	AF Series
4	AK Series
6	BF Series
8	BK Series
10	EF Series
11	EK Series
13	FF Series
15	FK Series
17	Support kits for miniature ball screws
18	WBK Series Heavy Load
20	Lock Nut
21	Suggested Mounting End

Support Unit

AF Series

Order Coding	Model No.	Surface treatment	Applicable ballscrew accuracy grade	Bearing
AF10_C7	AF10	Black Oxide	C7	608ZZ
AF10_C3			C3	608ZZ
AF10_C7N		Electyless Nickel Plating	C7	608DD
AF10_C3N			C3	608DD
AF12_C7	AF12	Black Oxide	C7	6000ZZ
AF12_C3			C3	6000ZZ
AF12_C7N		Electyless Nickel Plating	C7	6000DDU
AF12_C3N			C3	6000DDU
AF15_C7	AF15	Black Oxide	C7	6002ZZ
AF15_C3			C3	6002ZZ
AF15_C7N		Electyless Nickel Plating	C7	6002DDU
AF15_C3N			C3	6002DDU
AF20_C7	AF20	Black Oxide	C7	6204ZZ
AF20_C3			C3	6204ZZ
AF20_C7N		Electyless Nickel Plating	C7	6204DDU
AF20_C3N			C3	6204DDU

1. It is used double pressed steel cages for Black Oxide type support units.
2. It is used double plastic cages for Electroless Nickel Plating type support units.
3. All of bearings Use Japan' s brand bearings.



Black Oxide
(Fit for normal conditions)

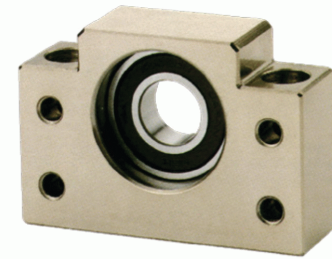

Nickel Plating
(fit for dust-free conditions)

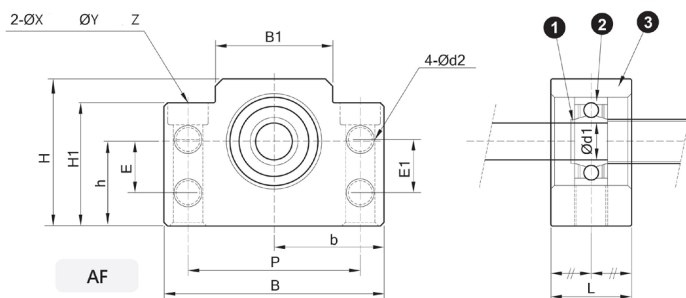

Part No.	Part name	Qty
1	Block Body	1 pc
2	Bearing	1 set
3	C-Rings	1 pc

Unit: mm

Model No	d1	L	B	H	b		B1	H1	E1	P	d2	X	Y	Z	E	Bearing	C-ring
					0.02	0.02											
AF10	8	20	60	43	35	25	36	35	19	52	6.5	9	14	11	15	608ZZ	S 08
AF12	10	20	60	43	35	25	36	35	19	52	6.5	9	14	11	15	6000ZZ	S 10
AF15	15	20	80	49	40	30	41	40	19	60	6.5	9	14	11	15	6002ZZ	S 15
AF20	20	26	95	58	47.5	30	56	45	19	75	6.5	11	17	15	15	6204ZZ	S 20

Support Unit

AK Series

Order Coding	Model No.	Surface treatment	Applicable ballscrew accuracy grade	Bearing
AK10_C7	AK10	Black Oxide	C7	7000A P0
AK10_C5			C5	
AK10_C3			C3	7000A P5
AK10_C7N		Electyless Nickel Plating	C7	7000A P0
AK10_C5N			C5	7000A P5
AK10_C3N			C3	
AK12_C7	AK12	Black Oxide	C7	7001A P0
AK12_C5			C5	
AK12_C3			C3	7001A P5
AK12_C7N		Electyless Nickel Plating	C7	7001A P0
AK12_C5N			C5	7001A P5
AK12_C3N			C3	
AK15_C7	AK15	Black Oxide	C7	7002A P0
AK15_C5			C5	
AK15_C3			C3	7002A P5
AK15_C7N		Electyless Nickel Plating	C7	7002A P0
AK15_C5N			C5	7002A P5
AK15_C3N			C3	
AK20_C7	AK20	Black Oxide	C7	7204A P0
AK20B_C7			C7	7204B P0
AK20_C5			C5	7204A P0
AK20B_C5			C5	7204B P0
AK20_C3			C3	7204A P5
AK20_C7N		Electyless Nickel Plating	C7	7204A P0
AK20B_C7N			C7	7204B P0
AK20_C5N			C5	7204A P0
AK20B_C5N			C5	7204B P0
AK20_C3N			C3	7204A P5

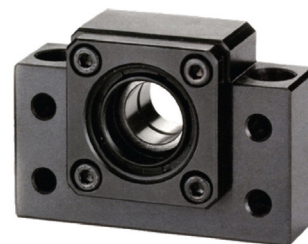

Black Oxide
(Fit for normal conditions)

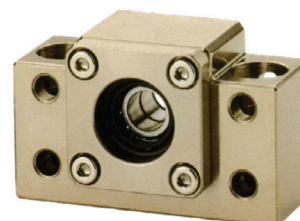

Nickel Plating
(fit for dust-free conditions)

1. It is used double pressed steel cages for Black Oxide type support units.
2. It is used double plastic cages for Electroless Nickel Plating type support units.
3. All of bearings Use Japan' s brand bearings.

Support Unit

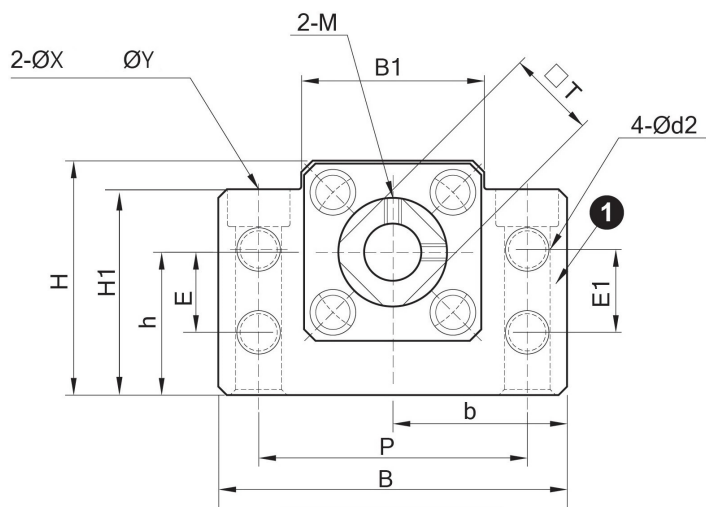

AK10~AK20

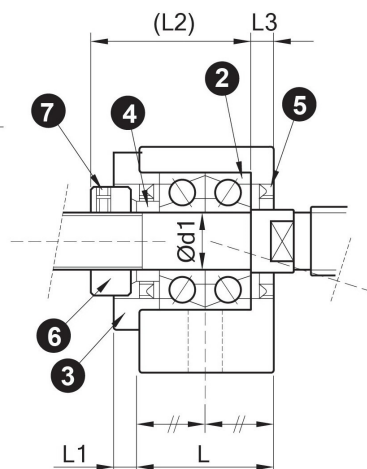

AK10~AK25

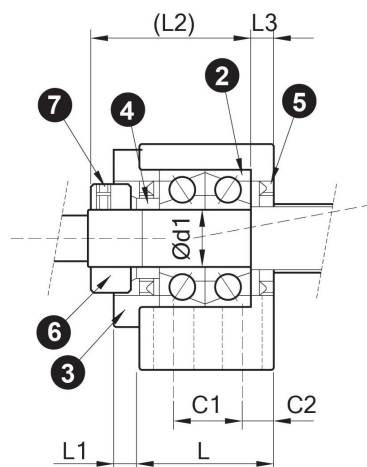

AK20

Part No.	Part name	Qty
1	Block Body	1 pc
2	Bearing	1set
3	Binder Pate	1 pc
4	Distance Ring	2 pcs
5	Seal	2 pcs
6	Lock Nut	1 set
7	Hexagon Socket Set Screw	2 pcs

Unit: mm

Model No.	d1	L	L1	L2	L3	B	H	b		B1	H1	E1	P	d2	X	Y	Z	M	T	E	C1	C2
								0.02	0.02													
AK10	10	24	6	30	6	70	43	35	25	36	35	19	52	6.5	9	14	11	M3	16	15	-	-
AK12	12	24	6	30	6	70	43	35	25	36	35	19	52	6.5	9	14	11	M4	19	15	-	-
AK15	15	25	6	36	5	80	49	40	30	41	40	19	60	6.5	11	17	15	M4	22	15	-	-
AK17	20	42	10	50	10	95	58	48	30	56	45	19	75	6.5	11	17	15	M4	30	15	22	10

Support Unit

BF Series

Order Coding	Model No.	Surface treatment	Applicable ballscrew accuracy grade	Bearing
BF10_C7	BF10	Black Oxide	C7	608ZZ
BF10_C3			C3,C5	608ZZ
BF10_C7N		Electyless Nickel Plating	C7	608DD
BF10_C3N			C3,C5	608DD
BF12_C7	BF12	Black Oxide	C7	6000ZZ
BF12_C3			C3,C5	6000ZZ
BF12_C7N		Electyless Nickel Plating	C7	6000DDU
BF12_C3N			C3,C5	6000DDU
BF15_C7	BF15	Black Oxide	C7	6002ZZ
BF15_C3			C3,C5	6002ZZ
BF15_C7N		Electyless Nickel Plating	C7	6002DDU
BF15_C3N			C3,C5	6002DDU
BF17_C7	BF17	Black Oxide	C7	6203ZZ
BF17_C3			C3,C5	6203ZZ
BF17_C7N		Electyless Nickel Plating	C7	6203DDU
BF17_C3N			C3,C5	6203DDU
BF20_C7	BF20	Black Oxide	C7	6004ZZ
BF20_C3			C3,C5	6004ZZ
BF20_C7N		Electyless Nickel Plating	C7	6004DDU
BF20_C3N			C3,C5	6004DDU
BF25_C7	BF25	Black Oxide	C7	6205ZZ
BF25_C3			C3,C5	6205ZZ
BF25_C7N		Electyless Nickel Plating	C7	6205DDU
BF25_C3N			C3,C5	6205DDU
BF30_C7	BF30	Black Oxide	C7	6206ZZ
BF30_C3			C3,C5	6206ZZ
BF30_C7N		Electyless Nickel Plating	C7	6206DDU
BF30_C3N			C3,C5	6206DDU
BF35_C7	BF35	Black Oxide	C7	6207ZZ
BF35_C3			C3,C5	6207ZZ
BF35_C7N		Electyless Nickel Plating	C7	6207DDU
BF35_C3N			C3,C5	6207DDU
BF40_C7	BF40	Black Oxide	C7	6208ZZ
BF40_C3			C3,C5	6208ZZ
BF40_C7N		Electyless Nickel Plating	C7	6208DDU
BF40_C3N			C3,C5	6208DDU



Black Oxide
(Fit for normal conditions)

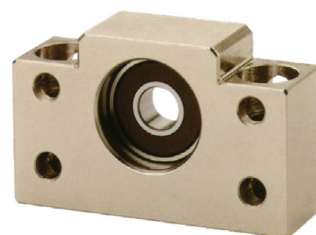

Nickel Plating
(fit for dust-free conditions)

1. It is used double pressed steel cages for Black Oxide type support units.
2. It is used double plastic cages for Electroless Nickel Plating type support units.
3. All of bearings Use Japan's brand bearings.

Support Unit

Part No.	Part name	Qty
1	Block Body	1 pc
2	Bearing	1 set
3	C-Rings	1 pc

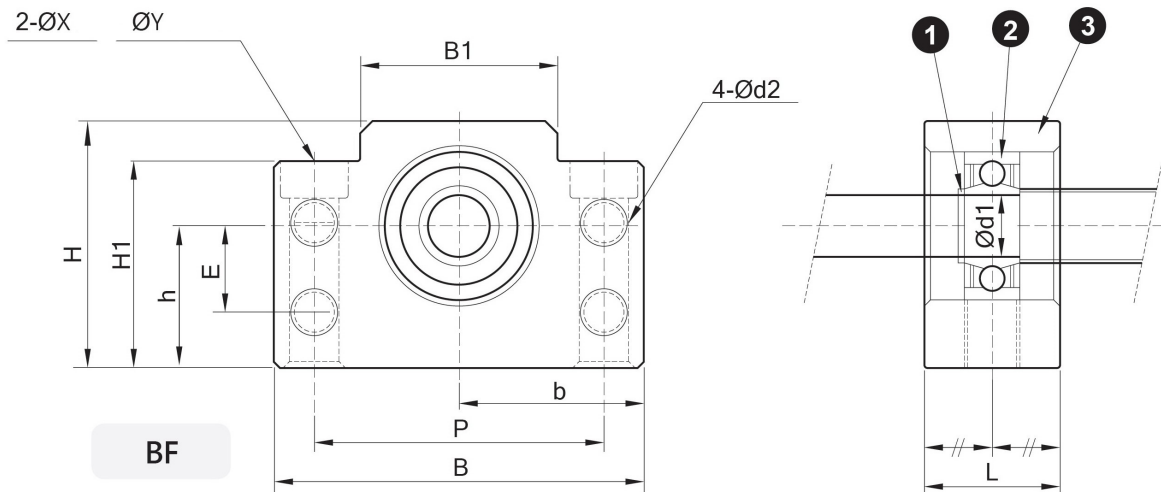

Model No.	d1	L	B	H	b	h	B1	H1	E	P	d2	X	Y	Z	Bearing	C-ring
					0.02	0.02										
BF10	8	20	60	39	30	22	34	33	15	46	5.50	6.60	10.80	5.00	608ZZ	S 08
BF12	10	20	60	43	30	25	34	33	18	46	5.50	6.60	10.80	1.50	6000ZZ	S 10
BF15	15	20	70	48	35	28	40	38	18	54	5.50	6.60	11.00	6.50	6002ZZ	S 15
BF17	17	23	86	64	43	39	50	55	28	68	6.60	9.00	14.00	8.50	6203ZZ	S 17
BF20	20	26	88	60	44	34	52	50	22	70	6.60	9.00	14.00	8.50	6004ZZ	S 20
BF25	25	30	106	80	53	48	64	70	33	85	9.00	11.00	17.50	11.00	6205ZZ	S 25
BF30	30	32	128	89	64	51	76	78	33	102	11.00	14.00	20.00	13.00	6206ZZ	S 30
BF35	35	32	140	96	70	52	88	79	35	114	11.00	14.00	20.00	13.00	6207ZZ	S 35
BF40	40	37	160	110	80	60	100	90	37	130	14.00	18.00	26.00	17.50	6208ZZ	S 40

Support Unit

BK Series



Black Oxide
(Fit for normal conditions)

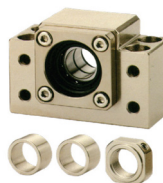

Nickel Plating
(fit for dust-free conditions)

Order Coding	Model No.	Surface treatment	Applicable ballscrew accuracy grade	Bearing
BK10_C7	BK10	Black Oxide	C7	7000A P0
BK10_C5			C5	
BK10_C3			C3	
BK10_C7N		Electyless Nickel Plating	C7	7000A P0
BK10_C5N			C5	
BK10_C3N			C3	
BK12_C7	BK12	Black Oxide	C7	7001A P0
BK12_C5			C5	
BK12_C3			C3	
BK12_C7N		Electyless Nickel Plating	C7	7001A P0
BK12_C5N			C5	
BK12_C3N			C3	
BK15_C7	BK15	Black Oxide	C7	7002A P0
BK15_C5			C5	
BK15_C3			C3	
BK15_C7N		Electyless Nickel Plating	C7	7002A P0
BK15_C5N			C5	
BK15_C3N			C3	
BK17_C7	BK17	Black Oxide	C7	7203A P0
BK17_C5			C5	
BK17_C3			C3	
BK17_C7N		Electyless Nickel Plating	C7	7203A P0
BK17_C5N			C5	
BK17_C3N			C3	
BK20_C7	BK20	Black Oxide	C7	7004A P0
BK20_C5			C5	
BK20_C3			C3	
BK20_C7N		Electyless Nickel Plating	C7	7004A P0
BK20_C5N			C5	
BK20_C3N			C3	

Order Coding	Model No.	Surface treatment	Applicable ballscrew accuracy grade	Bearing
BK25_C7	BK25	Black Oxide	C7	7205A P0
BK25B_C7			C7	7205B P0
BK25_C5			C5	7205A P0
BK25B_C5		C5	7205B P0	
BK25_C3		C3	7205A P5	
BK25_C7N		Electyless Nickel Plating	C7	7205A P0
BK25B_C7N	C7		7205B P0	
BK25_C5N	C5		7205A P0	
BK25B_C5N	C5		7205B P0	
BK25_C3N	C3	7205A P5		
BK30_C7	BK30	Black Oxide	C7	7206A P0
BK30B_C7			C7	7206B P0
BK30_C5			C5	7206A P0
BK30B_C5		C5	7206B P0	
BK30_C3		C3	7206A P5	
BK30_C7N		Electyless Nickel Plating	C7	7206A P0
BK30B_C7N	C7		7206B P0	
BK30_C5N	C5		7206A P0	
BK30B_C5N	C5		7206B P0	
BK30_C3N	C3	7206A P5		
BK35_C7	BK35	Black Oxide	C7	7207B P0
BK35_C5			C5	
BK35_C3			C3	7207B P5
BK35_C7N		Electyless Nickel Plating	C7	7207B P0
BK35_C5N			C5	
BK35_C3N			C3	7207B P5
BK40_C7	BK40	Black Oxide	C7	7208B P0
BK40_C5			C5	
BK40_C3			C3	7208B P5
BK40_C7N		Electyless Nickel Plating	C7	7208B P0
BK40_C5N			C5	
BK40_C3N			C3	7208B P5

1. It is used double pressed steel cages for Black Oxide type support units.
2. It is used double plastic cages for Electroless Nickel Plating type support units.
3. All of bearings Use Japan's brand bearings.

Support Unit

Part No.	Part name	Qty
1	Block Body	1 pc
2	Bearing	1set
3	Binder Pate	1 pc
4	Distance Ring	2 pcs
5	Seal	2 pcs
6	Lock Nut	1 set
7	Hexagon Socket Set Screw	2 pcs

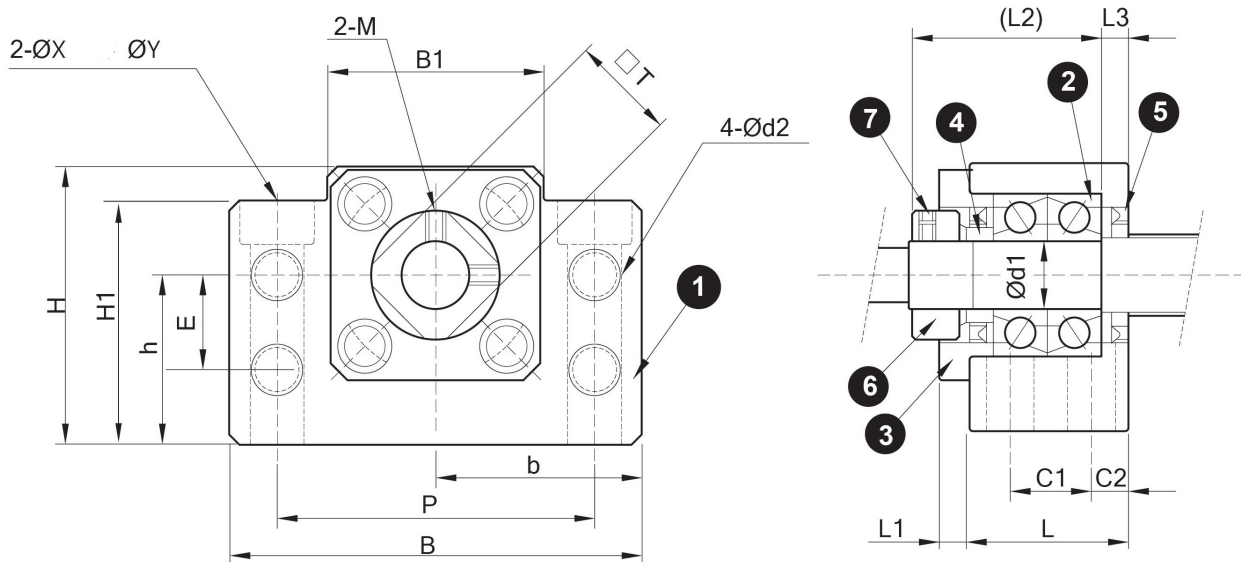

Model No.	d1	L	L1	L2	L3	B	H	b		h	B1	H1	E	P	C1	C2	d2	X	Y	Z	M	T
								0.02	0.02													
BK10	10	25	5	29	5	60	39	30	22	34	33	15	46	13	6	5.5	6.6	11	5	M3	16	
BK12	12	25	5	29	5	60	43	30	25	34	33	18	46	13	6	5.5	6.6	11	1.5	M4	19	
BK15	15	27	6	32	6	70	48	35	28	40	38	18	54	15	6	5.5	6.6	11	6.5	M4	22	
BK17	17	35	9	44	7	86	64	43	39	50	55	28	68	19	8	6.6	9	14	8.5	M4	24	
BK20	20	35	8	43	8	88	60	44	34	52	50	22	70	19	8	6.6	9	14	8.5	M4	30	
BK25	25	42	12	54	9	106	80	53	48	64	70	33	85	22	10	9	11	18	11	M5	35	
BK30	30	45	14	61	9	128	89	64	51	76	78	33	102	23	11	11	14	20	13	M6	40	
BK35	35	50	14	67	12	140	96	70	52	88	79	35	114	26	12	11	14	20	13	M8	50	
BK40	40	61	18	76	15	160	110	80	60	100	90	37	130	33	14	14	18	26	18	M8	50	

Support Unit

EF Series

Order Coding	Model No.	Surface treatment	Applicable ballscrew accuracy grade	Bearing
EF06_C7	EF06	Black Oxide	C7	606ZZ
EF06_C3			C3	606ZZ
EF06_C7N		Electyless Nickel Plating	C7	606VV
EF06_C3N			C3	606VV
EF08_C7	EF08	Black Oxide	C7	606ZZ
EF08_C3			C3	606ZZ
EF08_C7N		Electyless Nickel Plating	C7	606VV
EF08_C3N			C3	606VV
EF10_C7	EF10	Black Oxide	C7	608ZZ
EF10_C3			C3	608ZZ
EF10_C7N		Electyless Nickel Plating	C7	608DD
EF10_C3N			C3	608DD
EF12_C7	EF12	Black Oxide	C7	6000ZZ
EF12_C3			C3	6000ZZ
EF12_C7N		Electyless Nickel Plating	C7	6000DDU
EF12_C3N			C3	6000DDU
EF15_C7	EF15	Black Oxide	C7	6002ZZ
EF15_C3			C3	6002ZZ
EF15_C7N		Electyless Nickel Plating	C7	6002DDU
EF15_C3N			C3	6002DDU
EF20_C7	EF20	Black Oxide	C7	6204ZZ
EF20_C3			C3	6204ZZ
EF20_C7N		Electyless Nickel Plating	C7	6204DDU
EF20_C3N			C3	6204DDU

All of bearings Use Japan's brand bearings.

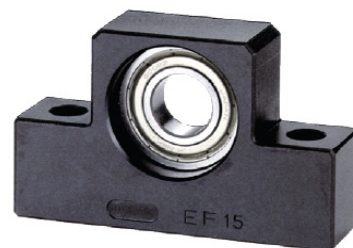

Black Oxide
(Fit for normal conditions)

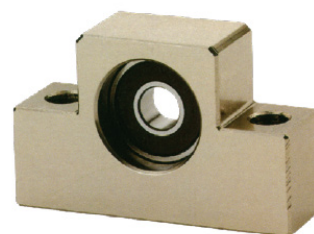

Nickel Plating
(fit for dust-free conditions)

Part No.	Part name	Qty
1	Block Body	1 pc
2	Bearing	1set
3	C-ring	1 pc

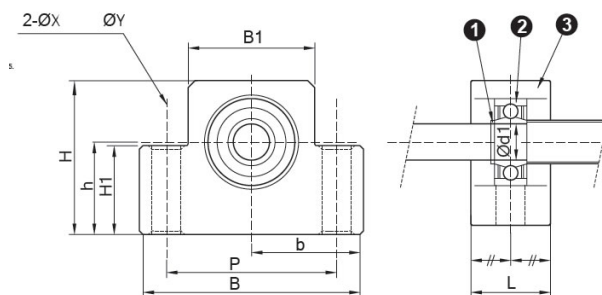

Model No.	d1	L	B	H	b	h	B1	H1	P	X	Y	Z	Bearing	C-ring
					0.02	0.02								
EF06	6	12	42	25	21	13	18	20	30	5.5	9.5	11	606ZZ	S06
EF08	8	14	52	32	36	17	25	26	38	6.6	11	12	606ZZ	S06
EF10	10	20	70	43	35	25	36	24	52	9	-	-	608ZZ	S08
EF12	12	20	70	43	35	25	36	24	52	9	-	-	6000ZZ	S10
EF15	15	20	80	49	40	30	41	25	60	11	-	-	6002ZZ	S15
EF20	20	26	95	58	47.5	30	56	25	75	11	-	-	6204ZZ	S20

Support Unit

EK Series

Order Coding	Model	Surface treatment	Applicable ballscrew accuracy grade	Bearing
EK05_C5	EK05	Black Oxide	C7	605
EK05_C5N		Electyless Nickel Plating	C7	605
EK06_C7	EK06	Black Oxide	C7	606
EK06_C5			C5	706A P0
EK06_C3			C3	706A P5
EK06_C7N		Electyless Nickel Plating	C7	606
EK06_C5N			C5	706A P0
EK06_C3N			C3	706A P5
EK08_C7			EK08	Black Oxide
EK08_C5	C5	708A P0		
EK08_C3	C3	708A P5		
EK08_C7N	Electyless Nickel Plating	C7		608
EK08_C5N		C5		708A P0
EK08_C3N		C3		708A P5
EK10_C7		EK10		Black Oxide
EK10_C5	C5			
EK10_C3	C3		7000A P5	
EK10_C7N	Electyless Nickel Plating		C7	7000A P0
EK10_C5N			C5	
EK10_C3N			C3	7000A P5
EK12_C7			EK12	Black Oxide
EK12_C5	C5			
EK12_C3	C3	7001A P5		
EK12_C7N	Electyless Nickel Plating	C7		7001A P0
EK12_C5N		C5		
EK12_C3N		C3		7001A P5
EK15_C7		EK15		Black Oxide
EK15_C5	C5			
EK15_C3	C3		7002A P5	
EK15_C7N	Electyless Nickel Plating		C7	7002A P0
EK15_C5N			C5	
EK15_C3N			C3	7002A P5
EK20_C7			EK20	Black Oxide
EK20B_C7	C7	7204B P0		
EK20_C5	C5	7204A P0		
EK20B_C5	C5	7204B P0		
EK20_C3	C3	7204A P5		
EK20_C7N	Electyless Nickel Plating	C7		
EK20B_C7N		C7		7204B P0
EK20_C5N		C5		7204A P0
EK20B_C5N		C5		7204B P0
EK20_C3N		C3		7204A P5

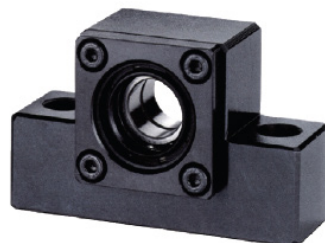

Black Oxide
(Fit for normal conditions)

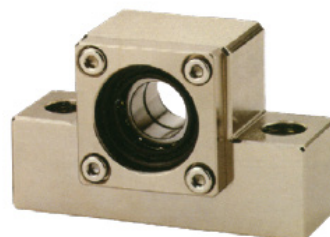

Nickel Plating
(fit for dust-free conditions)

1. Bearings are no Preload for C7 type support units, and Max. Axial clearance is 0.018mm
2. Bearings make Preload for C5 type support units, and Axial clearance is 0mm.
3. All of bearings Use Japan's brand bearings.

Support Unit

Part No.	Part name	Qty
1	Block Body	1 pc
2	Bearing	1set
3	Binder Pate	1 pc
4	Distance Ring	2 pcs
5	Seal	2 pcs
6	Lock Nut	1 set
7	Hexagon Socket Set Screw	2 pcs

EK06, EK08

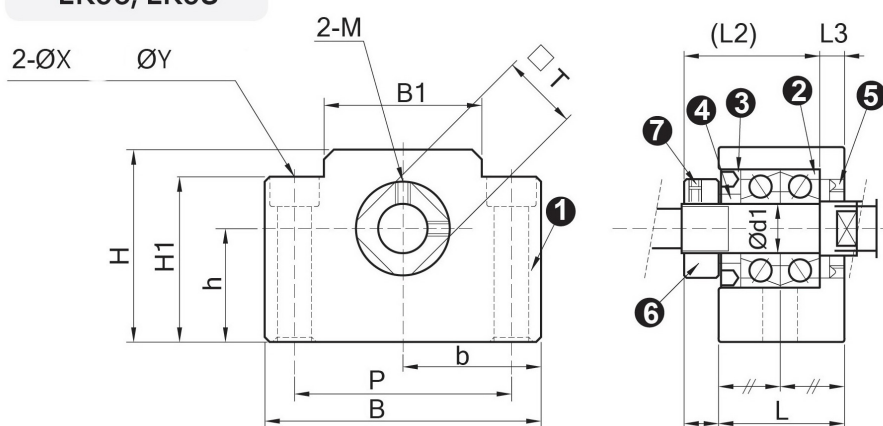

EK10~EK20

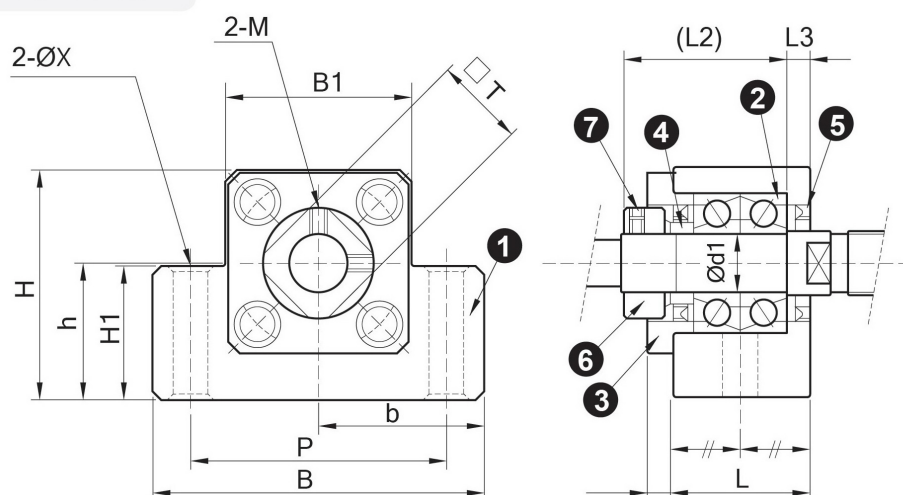

Model No	d1	L	L1	L2	L3	B	H	b		B1	H1	P	X	Y	Z	M	T
								0.02	0.02								
EK05	5	17	5.5	19	3.5	26	21	18	11	20	8	28	4.5	-	-	M3	11
EK06	6	20	5.5	22	3.5	42	25	21	13	18	20	30	5.5	9.5	11	M3	12
EK08	8	23	7	26	4	52	32	36	17	25	26	38	6.6	11	12	M3	14
EK10	10	24	6	30	6	70	43	35	25	36	24	52	9	-	-	M3	16
EK12	12	24	6	30	6	70	43	35	25	36	24	52	9	-	-	M4	19
EK15	15	25	6	36	5	80	49	40	30	41	25	60	11	-	-	M4	22
EK20	20	42	10	50	10	95	58	47.5	30	56	25	75	11	-	-	M4	30

Support Unit

FF Series

Order Coding	Model	Surface treatment	Applicable ballscrew accuracy grade	Bearing
FF06_C7	FF06	Black Oxide	C7	606ZZ
FF06_C3			C3	606ZZ
FF06_C7N		Electyless Nickel Plating	C7	606VV
FF06_C3N			C3	606VV
FF10_C7	FF10	Black Oxide	C7	608ZZ
FF10_C3			C3	608ZZ
FF10_C7N		Electyless Nickel Plating	C7	608DD
FF10_C3N			C3	608DD
FF12_C7	FF12	Black Oxide	C7	6000ZZ
FF12_C3			C3	6000ZZ
FF12_C7N		Electyless Nickel Plating	C7	6000DDU
FF12_C3N			C3	6000DDU
FF15_C7	FF15	Black Oxide	C7	6002ZZ
FF15_C3			C3	6002ZZ
FF15_C7N		Electyless Nickel Plating	C7	6002DDU
FF15_C3N			C3	6002DDU
FF17_C7	FF17	Black Oxide	C7	6203ZZ
FF17_C3			C3	6203ZZ
FF17_C7N		Electyless Nickel Plating	C7	6203DDU
FF17_C3N			C3	6203DDU
FF20_C7	FF20	Black Oxide	C7	6204ZZ
FF20_C3			C3	6204ZZ
FF20_C7N		Electyless Nickel Plating	C7	6204DDU
FF20_C3N			C3	6204DDU
FF25_C7	FF25	Black Oxide	C7	6205ZZ
FF25_C3			C3	6205ZZ
FF25_C7N		Electyless Nickel Plating	C7	6205DDU
FF25_C3N			C3	6205DDU
FF30_C7	FF30	Black Oxide	C7	6206ZZ
FF30_C3			C3	6206ZZ
FF30_C7N		Electyless Nickel Plating	C7	6206DDU
FF30_C3N			C3	6206DDU



Black Oxide
(Fit for normal conditions)

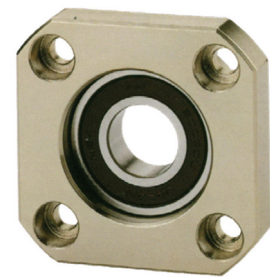

Nickel Plating
(fit for dust-free conditions)

1. Bearings are no Preload for C7 type support units, and Max. Axial clearance is 0.018mm
2. Bearings make Preload for C5 type support units, and Axial clearance is 0mm.
3. All of bearings Use Japan' s brand bearings.

Support Unit

Part No.	Part name	Qty
1	Block	1 pc
2	Bearing	1 Pair
3	C-Rings	1 pc

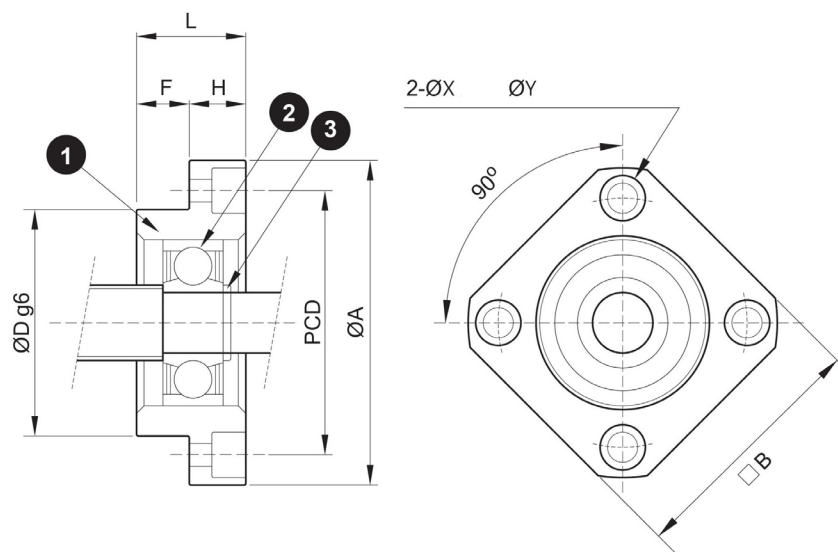

Model No	d1	L	H	F	Dg6		A	PCD	B	X	Y	Z	Bearing	C-ring
FF06	6	10	6	4	22	-0.007 -0.02	36	28	28	3.4	6.5	4	606ZZ	S 06
FF10	8	12	7	5	28	-0.007 -0.02	43	35	35	3.4	6.5	4	608ZZ	S 08
FF12	10	15	7	8	34	-0.009 -0.025	52	42	42	4.5	8	4	6000ZZ	S 10
FF15	15	17	9	8	40	-0.009 -0.025	63	50	52	5.5	9.5	5.5	6002ZZ	S 15
FF17	17	20	11	9	50	-0.009 -0.025	77	62	61	6.6	11	6.5	6203ZZ	S 17
FF20	20	20	11	9	57	-0.010 -0.029	85	70	68	6.6	11	6.5	6004ZZ	S 20
FF25	25	24	14	10	63	-0.010 -0.029	98	80	79	9	14	8.5	6205ZZ	S 25
FF30	30	27	18	9	75	-0.010 -0.029	117	95	93	11	17.5	11	6206ZZ	S 30

Support Unit

FK Series



Black Oxide
(Fit for normal conditions)



Nickel Plating
(fit for dust-free conditions)

Order Coding	Model	Surface treatment	Applicable ballscrew accuracy grade	Bearing
FK05_C7	FK05	Black Oxide	C7	605
FK05_C7N		Electyless Nickel Plating	C7	605
FK06_C7	FK06	Black Oxide	C7	606
FK06_C5			C5	706A P0
FK06_C3			C3	706A P5
FK06_C7N		Electyless Nickel Plating	C7	606
FK06_C5N			C5	706A P0
FK06_C3N			C3	706A P5
FK08_C7			FK08	Black Oxide
FK08_C5	C5	708A P0		
FK08_C3	C3	708A P5		
FK08_C7N	Electyless Nickel Plating	C7		608
FK08_C5N		C5		708A P0
FK08_C3N		C3		708A P5
FK10_C7	FK10	Black Oxide	C7	7000A P0
FK10_C5			C5	
FK10_C3			C3	7000A P5
FK10_C7N		Electyless Nickel Plating	C7	7000A P0
FK10_C5N			C5	7000A P0
FK10_C3N			C3	7000A P5
FK12_C7	FK12	Black Oxide	C7	7001A P0
FK12_C5			C5	
FK12_C3			C3	7001A P5
FK12_C7N		Electyless Nickel Plating	C7	7001A P0
FK12_C5N			C5	7001A P0
FK12_C3N			C3	7001A P5
FK15_C7	FK15	Black Oxide	C7	7002A P0
FK15_C5			C5	
FK15_C3			C3	7002A P5
FK15_C7N		Electyless Nickel Plating	C7	7002A P0
FK15_C5N			C5	7002A P0
FK15_C3N			C3	7002A P5

Order Coding	Model	Surface treatment	Applicable ballscrew accuracy grade	Bearing
FK17_C7	FK17	Black Oxide	C7	7203A P0
FK17_C5			C5	7203A P0
FK17_C3			C3	7203A P5
FK17_C7N		Electyless Nickel Plating	C7	7203A P0
FK17_C5N			C5	7203A P0
FK17_C3N			C3	7203A P5
FK20_C7	FK20	Black Oxide	C7	7204A P0
FK20B_C7			C7	7204B P0
FK20_C5			C5	7204A P0
FK20B_C5			C5	7204B P0
FK20_C3			C3	7204A P5
FK20_C7N		Electyless Nickel Plating	C7	7204A P0
FK20B_C7N			C7	7204B P0
FK20_C5N			C5	7204A P0
FK20B_C5N			C5	7204B P0
FK20_C3N			C3	7204A P5
FK25_C7	FK25	Black Oxide	C7	7205A P0
FK25B_C7			C7	7205B P0
FK25_C5			C5	7205A P0
FK25B_C5			C5	7205B P0
FK25_C3			C3	7205A P5
FK25_C7N		Electyless Nickel Plating	C7	7205A P0
FK25B_C7N			C7	7205B P0
FK25_C5N			C5	7205A P0
FK25B_C5N			C5	7205B P0
FK25_C3N			C3	7205A P5
FK30_C7	FK30	Black Oxide	C7	7206A P0
FK30B_C7			C7	7206B P0
FK30_C5			C5	7206A P0
FK30B_C5			C5	7206B P0
FK30_C3			C3	7206A P5
FK30_C7N		Electyless Nickel Plating	C7	7206A P0
FK30B_C7N			C7	7206B P0
FK30_C5N			C5	7206A P0
FK30B_C5N			C5	7206B P0
FK30_C3N			C3	7206A P5

Support Unit

Part No.	Part name	Qty
1	Block Body	1 pc
2	Bearing	1set
3	Binder Pate	1 pc
4	Distance Ring	2 pcs
5	Seal	2 pcs
6	Lock Nut	1 set
7	Hexagon Socket Set Screw	2 pcs

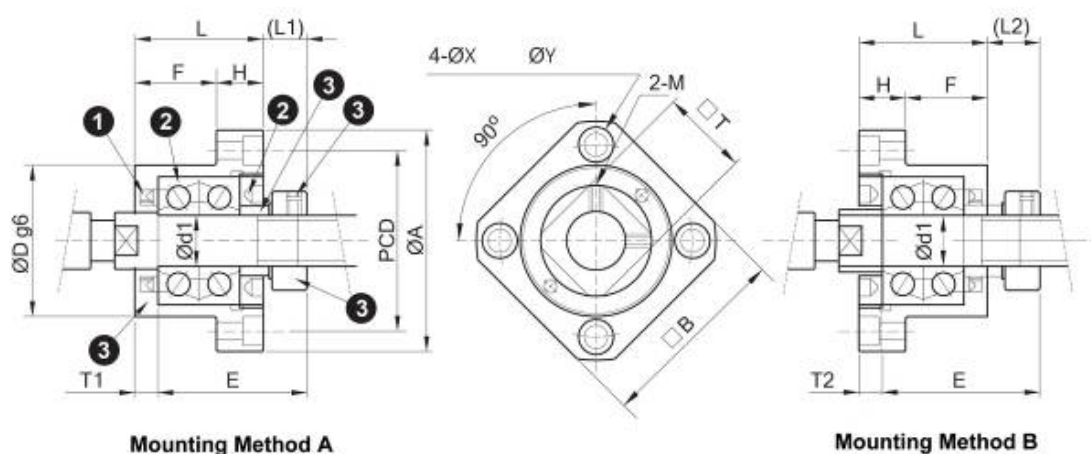

Model No	d1	L	H	F	E	Dg6	A	PCD	B	Mounting A		Mounting B		X	Y	Z	M	T	
										L1	T1	L2	T2						
FK05	5	17	6	11	19	20	-0.007 -0.02	34	26	26	5.5	3.5	7	5	3.4	6.5	4	M3	11
FK06	6	20	7	13	22	22	-0.007 -0.02	36	28	28	5.5	3.5	8.5	6.5	3.4	6.5	4	M3	12
FK08	8	23	9	14	26	28	-0.007 -0.02	43	35	35	7	4	10	7	3.4	6.5	4	M3	14
FK10	10	27	10	17	30	34	-0.009 -0.025	52	42	42	7.5	5	8.5	6	4.5	8	4	M3	16
FK12	12	27	10	17	30	36	-0.009 -0.025	54	44	44	7.5	5	8.5	6	4.5	8	4	M4	19
FK15	15	32	15	17	36	40	-0.009 -0.025	63	50	52	10	6	12	8	5.5	9.5	6	M4	22
FK17	17	45	22	23	47	50	-0.009 -0.025	77	62	61	11	9	14	12	6.6	11	10	M4	24
FK20	20	52	22	30	50	57	-0.010 -0.029	85	70	68	8	10	12	14	6.6	11	10	M4	30
FK25	25	57	27	30	60	63	-0.010 -0.029	98	80	79	13	10	20	17	9	15	13	M5	35
FK30	30	62	30	32	61	75	-0.010 -0.029	117	95	93	11	12	17	18	11	18	15	M6	40

Support Unit

Support kits for miniature ball screws (outer diameter 6mm,8mm ballscrew)

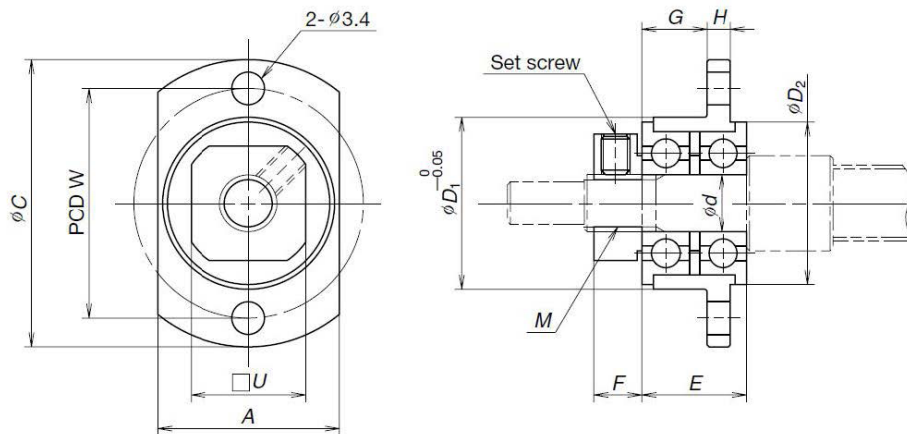

Reference no.	A	C	d	D1	D2	E	F	G	H	W	U	M
WBK04R-11	14	25	4	13	12.5	9	5	5	2.5	19	10	M4x0.5
WBK06R-11	19	30	6	18	17	11	5	6.8	2.5	24	12	M6x0.75

Reference no.	Applicable ballscrew	Locknut tightening torque (reference) [N · cm]	Setscrew tightening torque (reference) [N · cm]
WBK04R-11	MIF0601 MIA0601	147	38 (M2.5)
WBK06R-11	MIF0801 MIF0801.5 MIF0802	245	69 (M3)

Support Unit

WBK Series Heavy Load

Park No.	Part name	Qty
1	Block Body	1 pc
2	Bearing	1 set
3	Binder Pate	1 pc
4	Distance Ring	2 pcs
5	Seal	2 pcs

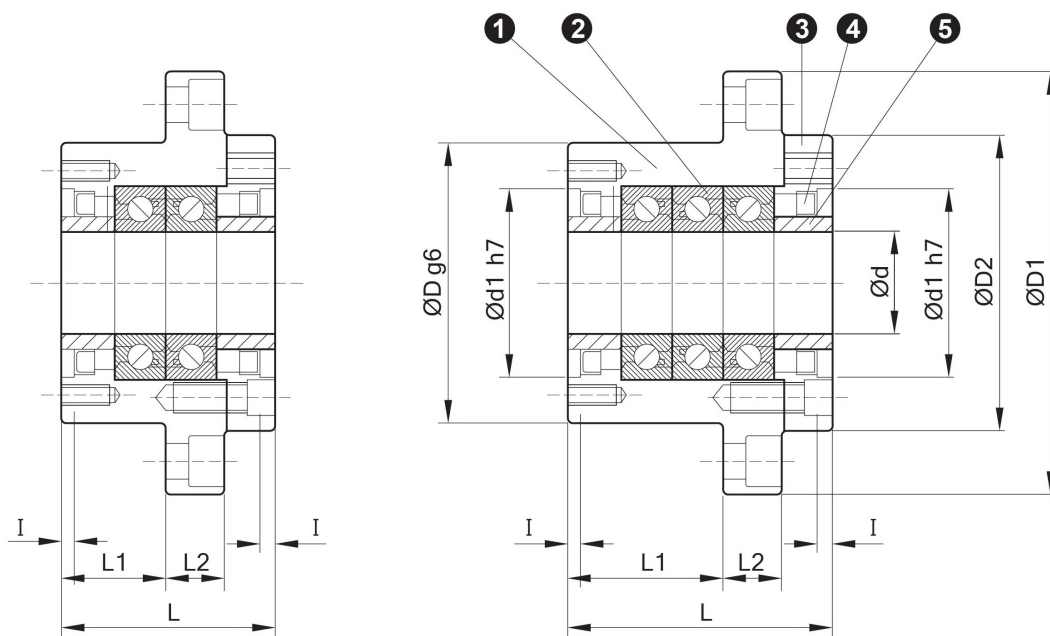
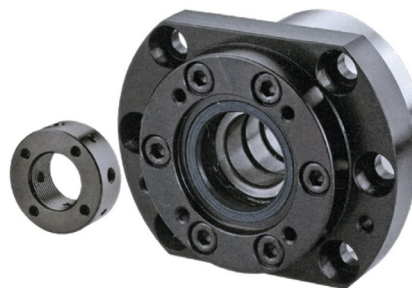

Model No	d	D	D1	D2	L	L1	L2	A	W	X	Y	Z	d1	l	V	P	Q
WBK 17DF	17	70	106	72	60	32	15	80	88	9	14	8.5	45	3	58	M5	10
WBK 20DF	20	70	106	72	60	32	15	80	88	9	14	8.5	45	3	58	M5	10
WBK 25DF	25	85	130	90	66	33	18	100	110	11	17.5	11	57	4	70	M6	12
WBK 25DF	25	85	130	90	81	48	18	100	110	11	17.5	11	57	4	70	M6	12
WBK 30DF	30	85	130	90	66	33	18	100	110	11	17.5	11	57	4	70	M6	12
WBK 30DF	30	85	130	90	81	48	18	100	110	11	17.5	11	57	4	70	M6	12
WBK 35DF	35	95	142	102	66	33	18	106	121	11	17.5	11	69	4	80	M6	12
WBK 35DF	35	95	142	102	81	48	18	106	121	11	17.5	11	69	4	80	M6	12
WBK 40DF	40	95	142	102	66	33	18	106	121	11	17.5	11	69	4	80	M6	12
WBK 40DF	40	95	142	102	81	48	18	106	121	11	17.5	11	69	4	80	M6	12

Support Unit

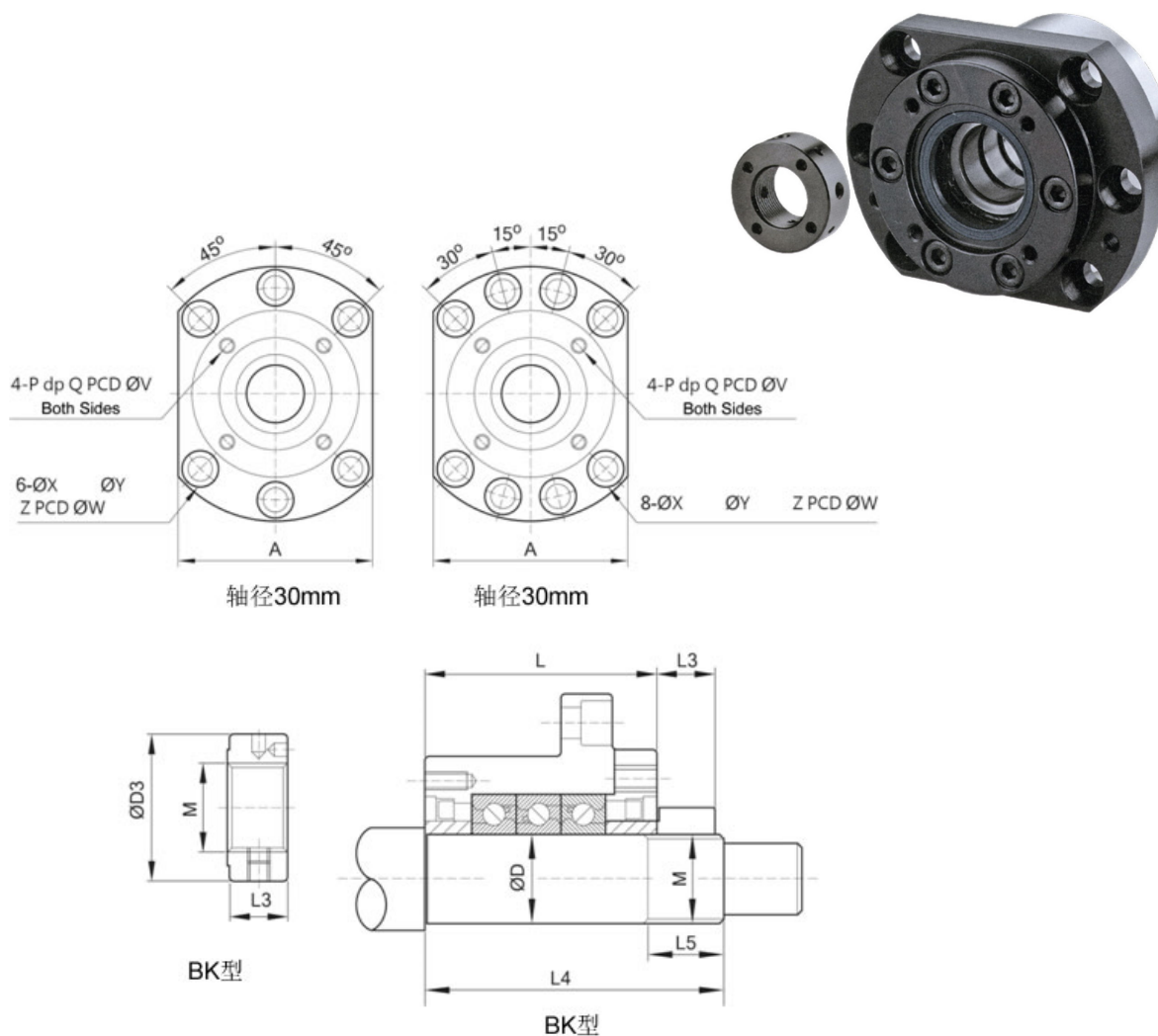

Model No	Bearing	Basic Lad-Ca (N)	Limit Load(N)	Preload (N)	Axial Stiffness (N/um)	Starting Torque (N-cm)	Lock nut			Weight (Kgs)	End Size		
							M	D3	L3		d	L4	L5
WBK 17DF	17TAC47 P4	21900	26600	2150	750	14	M17x1	37	18	1.9	17	81	23
WBK 20DF	20TAC47 P4	21900	26600	2150	750	14	M20x1	40	18	1.9	20	81	23
WBK 25DF	25TAC62 P4	28500	40500	3150	1000	23	M25x1.5	45	20	3.1	25	89	26
WBK 25DF	25TAC62 P4	46500	81500	4300	1470	31	M25x1.5	45	20	3.4	25	104	26
WBK 30DF	30TAC62 P4	29200	43000	3350	1030	24	M30x1.5	50	20	3.0	30	89	26
WBK 30DF	30TAC62 P4	47500	86000	4500	1520	33	M30x1.5	50	20	3.3	30	104	26
WBK 35DF	35TAC72 P4	31000	50000	3800	1180	28	M35x1.5	55	22	3.4	35	92	30
WBK 35DF	35TAC72 P4	50500	100000	5200	1710	37	M35x1.5	55	22	4.3	35	107	30
WBK 40DF	40TAC72 P4	31500	52000	3900	1230	28	M40x1.5	60	22	3.6	40	92	30
WBK 40DF	40TAC72 P4	51500	104000	5300	1810	38	M40x1.5	60	22	4.2	40	107	30

Support Unit

Lock Nut

Order Coding	Model No.	Surface treatment	Max Tightening (kgf-cm)
RN05	M5 x P0.5	Black Oxide	
RN05_N		Electyless Nickel Plating	
RN06	M6 x P0.75	Black Oxide	25
RN06_N		Electyless Nickel Plating	
RN08	M8 x P1.0	Black Oxide	50
RN08_N		Electyless Nickel Plating	
RN10	M10 x P1.0	Black Oxide	95
RN10_N		Electyless Nickel Plating	
RN12	M12 x P1.0	Black Oxide	140
RN12_N		Electyless Nickel Plating	
RN15	M15 x P1.0	Black Oxide	240
RN15_N		Electyless Nickel Plating	
RN17	M17 x P1.0	Black Oxide	
RN17_N		Electyless Nickel Plating	
RN17W	M17 x P1.0 (for WBK17-31)	Black Oxide	550
RN17W_N		Electyless Nickel Plating	
RN20	M20 x P1.0	Black Oxide	480
RN20_N		Electyless Nickel Plating	
RN20W	M20 x P1.0 (for WBK17-31)	Black Oxide	750
RN20W_N		Electyless Nickel Plating	
RN25	M25 x P1.5	Black Oxide	860
RN25_N		Electyless Nickel Plating	
RN25W	M25 x P1.5 (for WBK17-31)	Black Oxide	1350
RN25W_N		Electyless Nickel Plating	
RN30	M30 x P1.5	Black Oxide	
RN30_N		Electyless Nickel Plating	
RN30W	M30 x P1.5 (for WBK17-31)	Black Oxide	2000
RN30W_N		Electyless Nickel Plating	
RN35	M35 x P1.5	Black Oxide	
RN35_N		Electyless Nickel Plating	
RN35W	M35 x P1.5 (for WBK17-31)	Black Oxide	3000
RN35W_N		Electyless Nickel Plating	
RN40	M40 x P1.5	Black Oxide	
RN40_N		Electyless Nickel Plating	
RN40W	M40 x P1.5 (for WBK17-31)	Black Oxide	4000
RN40W_N		Electyless Nickel Plating	



Black Oxide
(Fit for normal conditions)



Nickel Plating
(fit for dust-free conditions)



Black Oxide
(Fit for normal conditions)

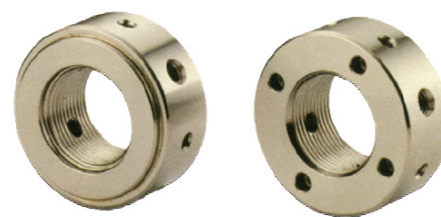

Nickel Plating
(fit for dust-free conditions)

Support Unit

Suggested Mounting End

BK Type

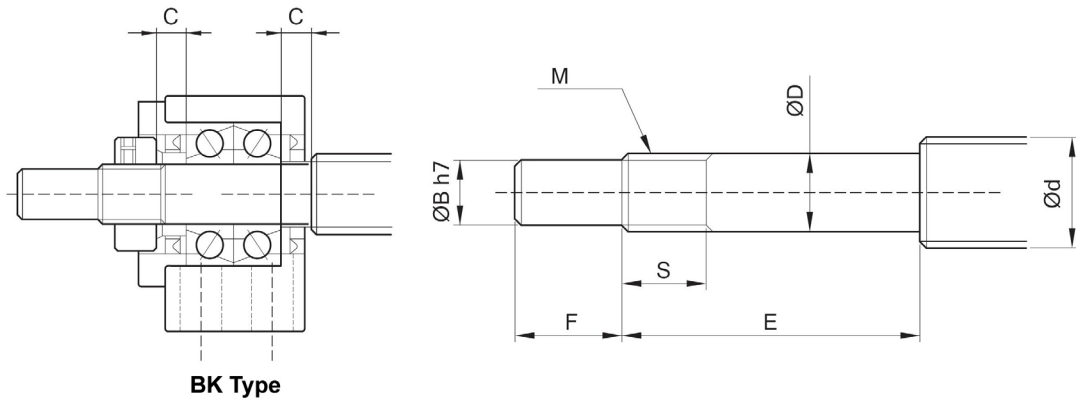

Model No	OD of the ballscrew	OD of the shaft end		B	E	F	Thread		Length of the Sleeve Nut
	d	D					M	S	C
BK10	12/14/15	10	-0.005	8	36	15	M10x1	16	5.5
			-0.012						
BK12	14/15/16	12	-0.005	10	36	15	M12x1	14	5.5
			-0.012						
BK15	18/20	15	-0.005	12	40	20	M15x1	12	6
			-0.014						
BK17	20/25	17	-0.005	15	53	23	M17x1	17	7
			-0.014						
BK20	25/28	20	-0.005	17	53	25	M20x1	15	8
			-0.014						
BK25	32/36	25	-0.005	20	65	30	M25x1.5	18	9
			-0.014						
BK30	36/40	30	-0.005	25	72	38	M30x1.5	25	9
			-0.015						
BK35	45	35	-0.005	30	81	45	M35x1.5	28	12
			-0.015						
BK40	50	40	-0.005	35	93	50	M40x1.5	35	15
			-0.015						

Support Unit

FK, EK, AK Type

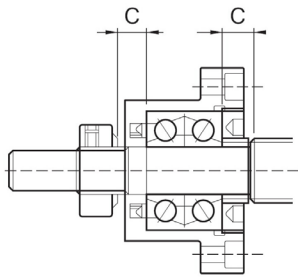
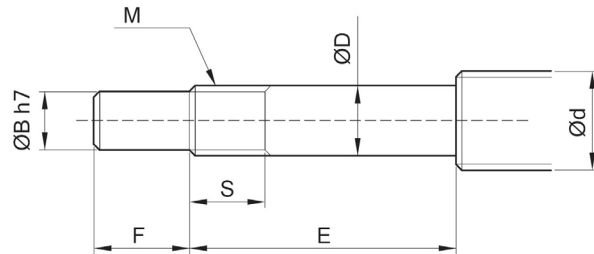

FK 型

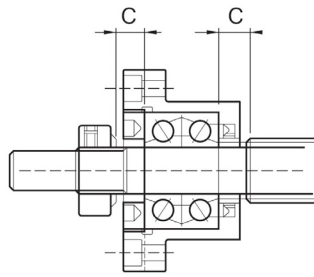

FK 型

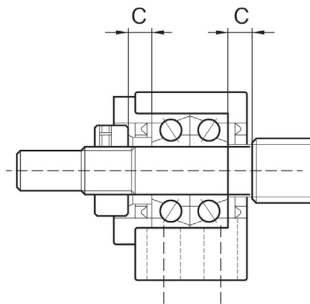

EK, AK 型

Model No			OD of the ballscrew d	OD of the shaft end		B	E	F	Thread		Length of the sleeve nut C
				D					M	S	
FK05	EK05	-	8	5	-0.005	4	25	6	M5x0.5	7	3.5
					-0.012						
FK06	EK06	-	8	6	-0.005	4	28	8	M6x0.75	8	5
					-0.012						
FK08	EK08	-	10/12	8	-0.005	6	32	9	M8x1	10	5.5
					-0.012						
FK10	EK10	AK10	12/14/15	10	-0.005	8	36	15	M10x1	11	5.5
					-0.012						
FK12	EK12	AK12	14/15/16	12	-0.005	10	36	15	M12x1	11	5.5
					-0.012						
FK15	EK15	AK15	18/20	15	-0.005	12	40	20	M15x1	13	10
					-0.014						
FK17	-	-	20/25	17	-0.005	15	53	23	M17x1	15	10
					-0.014						
FK20	EK20	AK20	25/28	20	-0.005	17	53	25	M20x1	17	11
					-0.014						
FK25	-	-	32/36	25	-0.005	20	65	30	M25x1.5	20	15
					-0.014						
FK30	-	-	36/40	30	-0.005	25	72	38	M30x1.5	25	9
					-0.015						

Support Unit

FF, EF, BF, AF Type

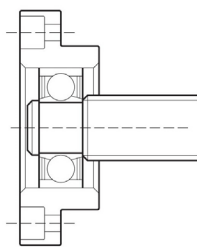
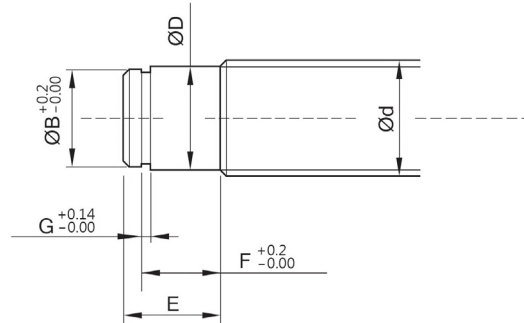

FF Type

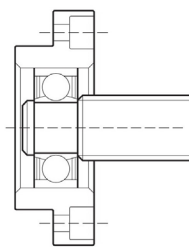

FF Type

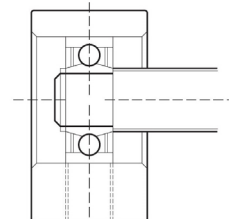

EF, BF, AF Types

Model No.				OD of the ballscrew	OD of the shaft end		E	B	F	G
				d	D					
FF06	EF06	-	-	8	6	-0.005 -0.012	9	5.7	6.8	0.8
-	EF08	-	-	10	6	-0.005 -0.012	9	5.7	6.8	0.8
FF10	EF10	BF10	AF10	12/14/15	8	-0.005 -0.012	10	7.6	7.9	0.9
FF12	EF12	BF12	AF12	14/15/16	10	-0.005 -0.012	11	9.6	9.15	1.15
FF15	EF15	BF15	AF15	18/20	15	-0.005 -0.014	13	14.3	10.15	1.15
FF17	-	BF17	-	20/25	17	-0.005 -0.014	16	16.2	13.15	1.15
FF20	EF20	BF20 *	AF20	25/28/30	20	-0.005 -0.014	19(16)	19	15.35(13.35)	1.35
FF25	-	BF25	-	30/32/36	25	-0.005 -0.014	20	23.9	16.35	1.35
FF30	-	BF30	-	36/40	30	-0.005 -0.015	21	28.6	17.75	1.75
-	-	BF35	-	40/45	35	-0.005 -0.015	22	33	18.75	1.75
-	-	BF40	-	50	40	-0.005 -0.015	23	38	19.75	1.95