



Auto Linear Motion

Ball Screw



ALM Intelligent Technology (Suzhou) Co., Limited

Add: No 1998 Jinfeng south road, Wuzhong district, Suzhou city, China

E-mail: sales@autolinearmotion.com

Tel: +8618962406535

Web: www.autolinearmotion.com

Ball Screw

2-1 Nominal Model Code of Ball Screw

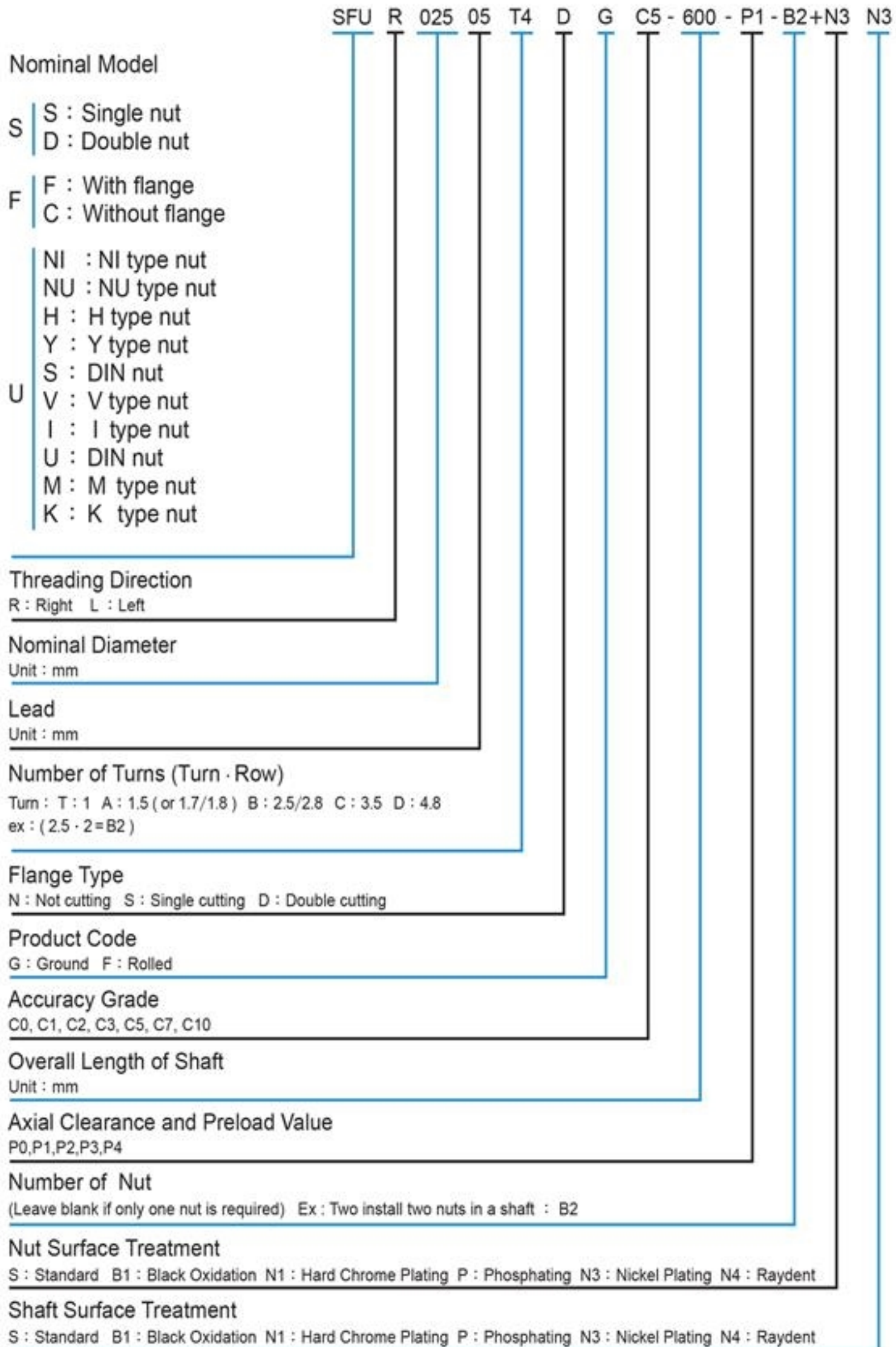

Ball Screw

SFK Series Specifications

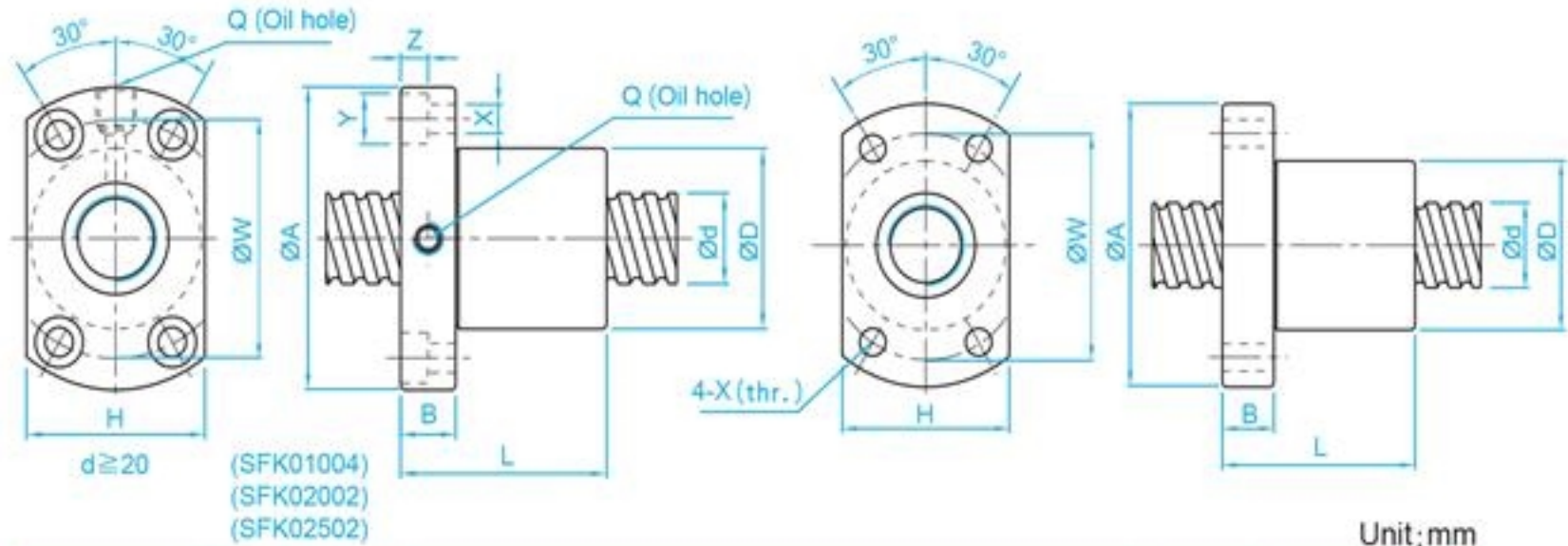

Unit: mm

Model No.	d	l	Da	Dimension											Ca (kgf)	Coa (kgf)	K (kgf/ μ m)
				D	A	B	L	W	H	X	Y	Z	Q	n			
SFK00401	4	1	0.8	10	20	3	12	15	14	2.9	-	-	-	1x2	64	97	5
SFK00601	6	1	0.8	12	24	3.5	15	18	16	3.4	-	-	-	1x3	111	224	9
☆ SFK00801	8	1	0.8	14	27	4	16	21	18	3.4	-	-	-	1x4	161	403	14
☆ SFK00802		2	1.2	14	27	4	16	21	18	3.4	-	-	-	1x3	222	458	13
SFK0082.5		2.5	1.2	16	29	4	26	23	20	3.4	-	-	-	1x3	221	457	13
☆ SFK01002	10	2	1.2	18	35	5	28	27	22	4.5	-	-	-	1x3	243	569	15
SFK01004		4	2	26	46	10	34	36	28	4.5	8	45	M6	1x3	468	905	17
☆ SFK01202	12	2	1.2	20	37	5	28	29	24	4.5	-	-	-	1x4	334	906	22
☆ SFK01402	14	2	1.2	21	40	6	23	31	26	5.5	-	-	-	1x4	354	1053	24
☆ SFK01602	16	2	1.2	25	43	10	40	35	29	5.5	-	-	M6	1x4	373	1200	26
SFK02002	20	2	1.2	50	80	15	55	65	68	6.5	10.5	6	M6	1x6	581	2284	48
SFK02502	25	2	1.2	50	80	13	43	65	68	6.5	10.5	6	M6	1x5	540	2381	46

※ ☆ Left helix available ※

Unit: mm

Model No.	d	l	Da	Dimension											Ca (kgf)	Coa (kgf)	K (kgf/ μ m)
				D	A	B	L	W	H	X	Y	Z	Q	n			
XSUR01204T3D-02	12	4	2.5	24	40	6	28	32	25	3.5	-	-	-	1x3	454	722	-
XSUR01205T3D-00		5	2.5	22	37	8	39	29	24	4.5	-	-	-	1x3	675	1316	17

Ball Screw

SCI Series Specifications

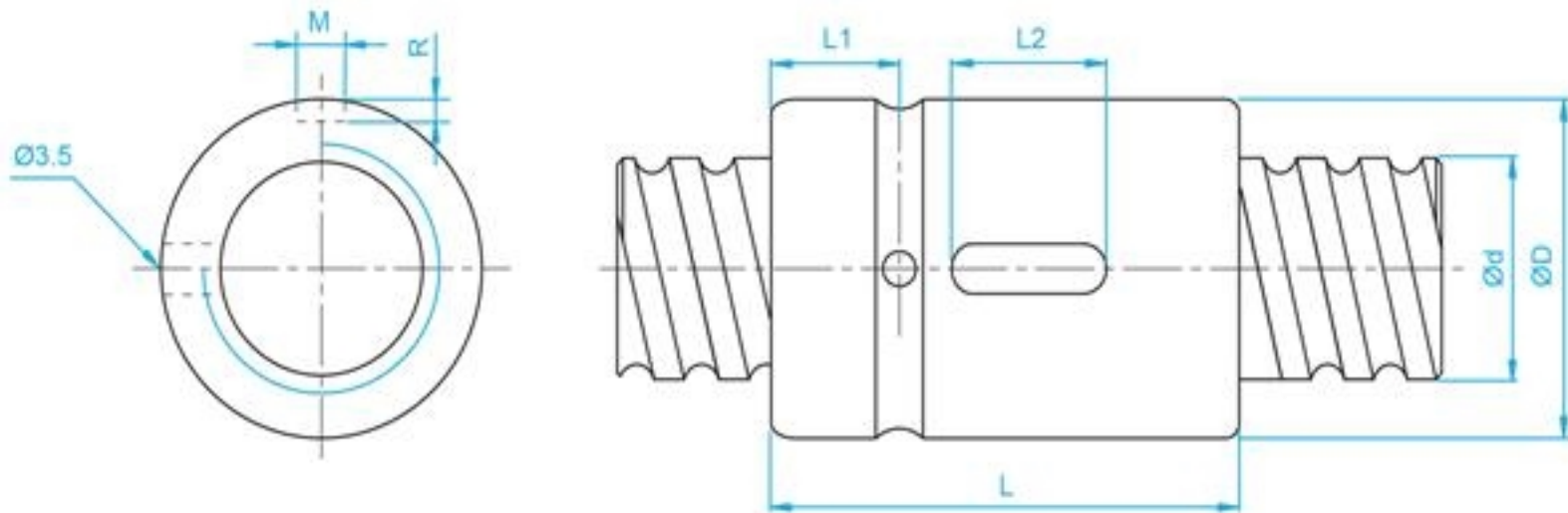

Unit: mm

Model No.	d	l	Da	Dimension							Ca (kgf)	Coa (kgf)	K kgf/ μ m
				D	L	L1	L2	M	R	n			
SCI01604-4	16	4	2.381	30	40	9	15	3	1.5	1x4	973	2406	32
☆ SCI01605-4		5	3.175	30	45	9	20	5	3	1x4	1380	3052	33
SCI02004-4	20	4	2.381	34	40	9	15	3	1.5	1x4	1066	2987	37
☆ SCI02005-4		5	3.175	34	45	9	20	5	3	1x4	1551	3875	39
SCI02504-4	25	4	2.381	40	40	9	15	3	1.5	1x4	1180	3795	43
☆ SCI02505-4		5	3.175	40	45	9	20	5	3	1x4	1724	4904	45
SCI02510-4		10	4.762	46	85	13	30	5	3	1x4	2954	7295	51
SCI03204-4	32	4	2.381	46	40	9	15	3	1.5	1x4	1296	4838	49
☆ SCI03205-4		5	3.175	46	45	9	20	5	3	1x4	1922	6343	52
☆ SCI03210-4		10	6.35	54	85	13	30	5	3	1x4	4805	12208	62
☆ SCI04005-4	40	5	3.175	56	45	9	20	5	3	1x4	2110	7988	59
☆ SCI04010-4		10	6.35	62	85	13	30	5	3	1x4	5399	15500	72
SCI05010-4	50	10	6.35	72	85	13	30	5	3	1x4	6004	19614	83
☆ SCI06310-4	63	10	6.35	85	85	13	30	6	3.5	1x4	6719	25358	95
☆ SCI08010-4	80	10	6.35	105	85	13	30	8	4.5	1x4	7346	31953	109

※☆Left helix available※

Ball Screw

BSH Series Specifications

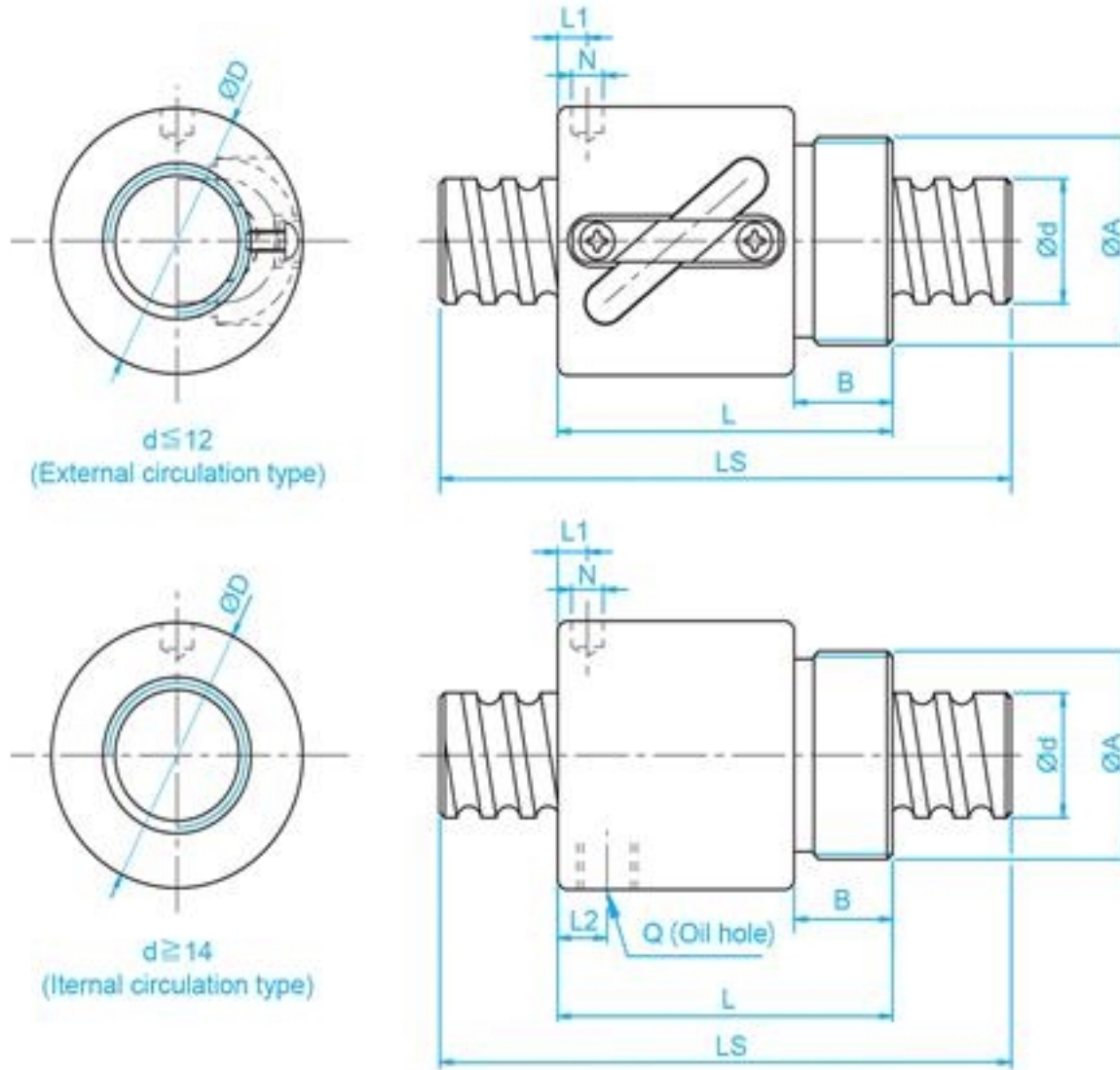

Unit: mm

Model No.	d	l	Da	Dimension									Ca (kgf)	Coa (kgf)	K kgf/ μm
				D	A	B	L	L1	N	L2	Q	n			
BSHR0082.5-2.5	8	2.5	1.2	17.5	M15x1P	7.5	23.5	10	3	-	-	2.5x1	189	381	11
BSHR01002-3.5	10	2	1.2	19.5	M17x1P	7.5	22	3	3.2	-	-	3.5x1	277	664	17
BSHR01004-2.5		4	2	25	M20x1P	10	34	3	3	-	-	2.5x1	400	754	14
BSHR01204-3.5	12	4	2.5	25.5	M20x1P	10	34	13	3	-	-	3.5x1	804	1649	23
BSHR01205-3.5		5	2.5	25.5	M20x1P	10	39	16.25	3	-	-	3.5x1	801	1644	24
BSHR01404-3	14	4	2.5	32.1	M25x1.5P	10	35	11	3	-	-	1x3	748	1609	26
BSHR01604-3	16	4	2.381	29	M22x1.5P	8	32	4	3.2	-	-	1x3	759	1804	24
BSHR01605-3		5	3.175	32.5	M26x1.5P	12	42	19.25	3	-	-	1x3	1077	2289	25
BSHR01610-2		10	3.175	32	M26x1.5P	12	50	3	4	3	M4	1x2	675	1316	14
BSHR02005-3	20	5	3.175	38	M35x1.5P	15	45	20.3	3	-	-	1x3	1211	2906	30
BSHR02505-4	25	5	3.175	43	M40x1.5P	19	69	32.11	3	8	M6	1x4	1724	4904	37
BSHR02510-4		10	4.762	43	M40x1.5P	19	84	8	6	8	M6	1x4	2954	7295	41

※Standard ballnut from Ø8~Ø16 is assembled without wiper. ※

Ball Screw

XSVR01210-01 Series Specifications (Finish Shaft Ends)

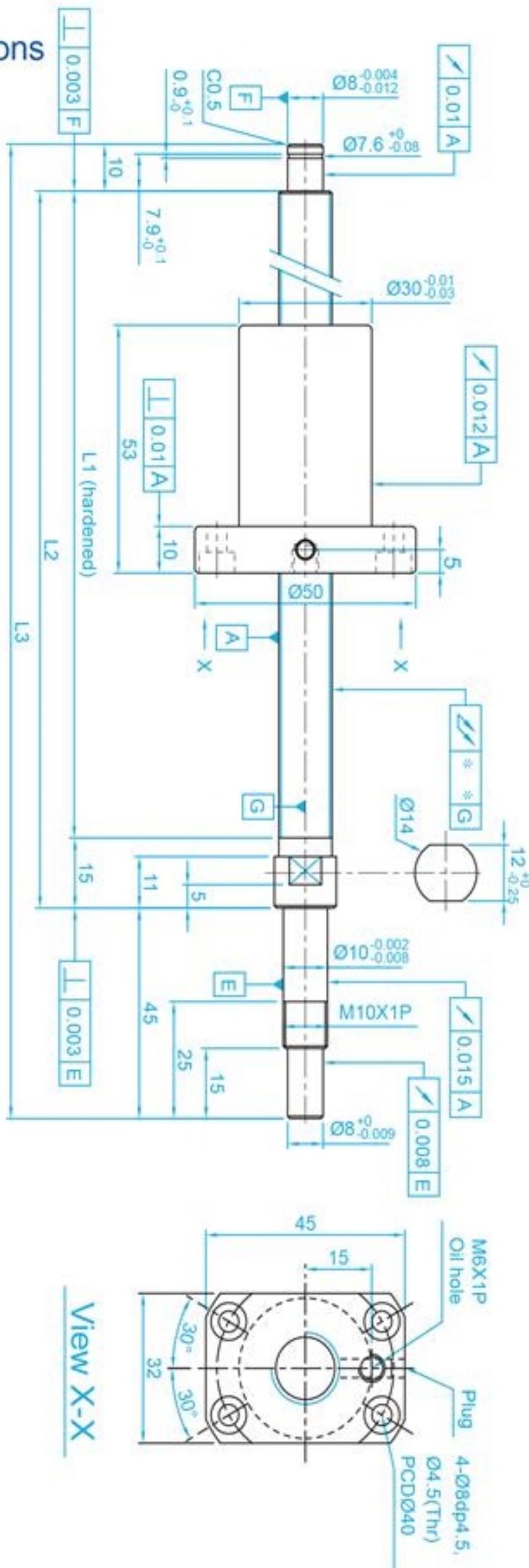

BCD	12.85
Ball Dia (mm)	2.5
Lead (mm)	10
No. of Turns	2.7x1
Lead Angle	13.91°
Threading Direction	R
Spring Force (kg)	0.1~0.2
Preload (kgf)	25
Dynamic Load Rating Ca (kgf)	623
Static Load Rating Coa (kgf)	1241
Accuracy Grade	0.018

Travel Length (mm)	Model No.	Shaft Length(mm)			Start of Axle Center
		L1	L2	L3	
100	XSVR01210B1DGC5-230-P1	160	175	230	0.035
150	XSVR01210B1DGC5-280-P1	210	225	280	0.035
250	XSVR01210B1DGC5-380-P1	310	325	380	0.050
350	XSVR01210B1DGC5-480-P1	410	425	480	0.060
450	XSVR01210B1DGC5-580-P1	510	525	580	0.075

Unit:mm

Ball Screw

XSVR01510-00 Series Specifications (Finish Shaft Ends)

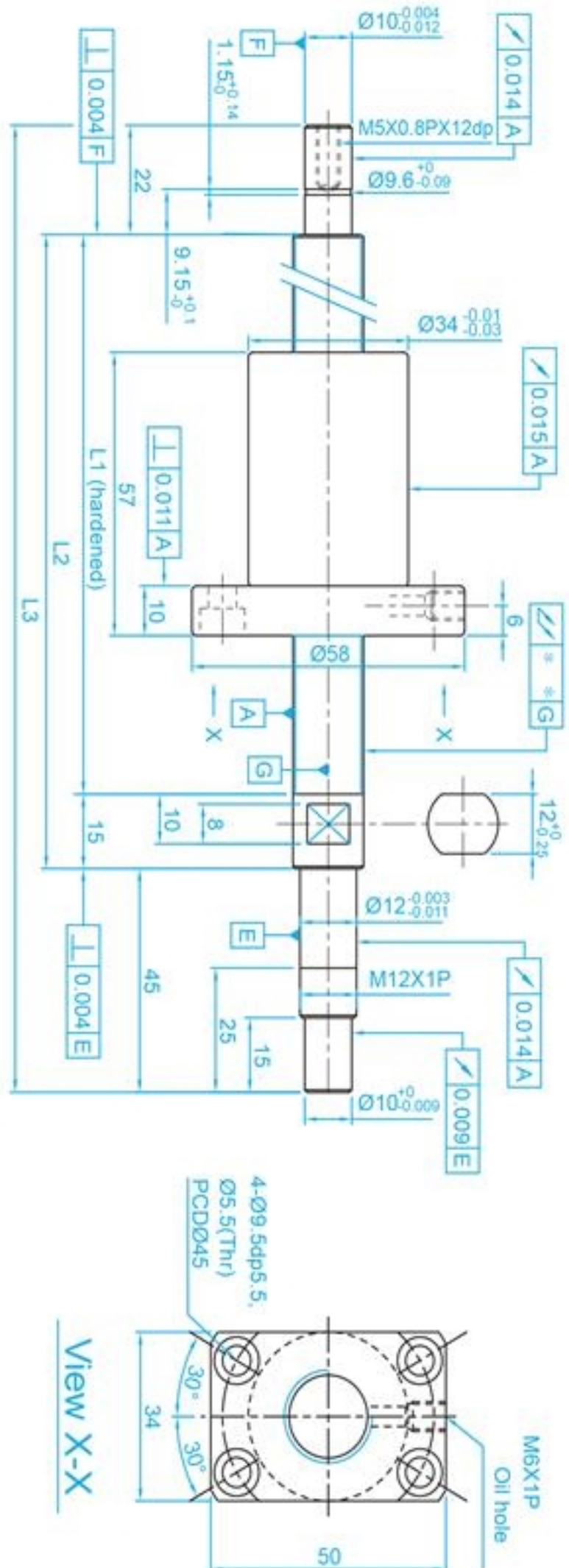

BCD	15.5
Ball Dia (mm)	3.175
Lead (mm)	10
No. of Turns	2.7x1
Lead Angle	11.6°
Threading Direction	R
Spring Force (kg)	0.1~0.3
Preload (kgf)	38
Dynamic Load Rating Ca (kgf)	933
Static Load Rating Coa (kgf)	1885
Accuracy Grade	0.018

Travel Length (mm)	Model No.	Shaft Length(mm)			Slant of Axle Center
		L1	L2	L3	
100	XSVR01510B1DGC5-271-P1	189	204	271	0.025
150	XSVR01510B1DGC5-321-P1	239	254	321	0.035
200	XSVR01510B1DGC5-371-P1	289	304	371	0.035
250	XSVR01510B1DGC5-421-P1	339	354	421	0.040
300	XSVR01510B1DGC5-471-P1	389	404	471	0.040
350	XSVR01510B1DGC5-521-P1	439	454	521	0.050
400	XSVR01510B1DGC5-571-P1	489	504	571	0.050
450	XSVR01510B1DGC5-621-P1	539	554	621	0.050
500	XSVR01510B1DGC5-671-P1	589	604	671	0.065
550	XSVR01510B1DGC5-721-P1	639	654	721	0.065
600	XSVR01510B1DGC5-771-P1	689	704	771	0.065
700	XSVR01510B1DGC5-871-P1	789	804	871	0.085
800	XSVR01510B1DGC5-971-P1	889	904	971	0.085

Unit: mm

Ball Screw

XSVR01520-01 Series Specifications (Finish Shaft Ends)

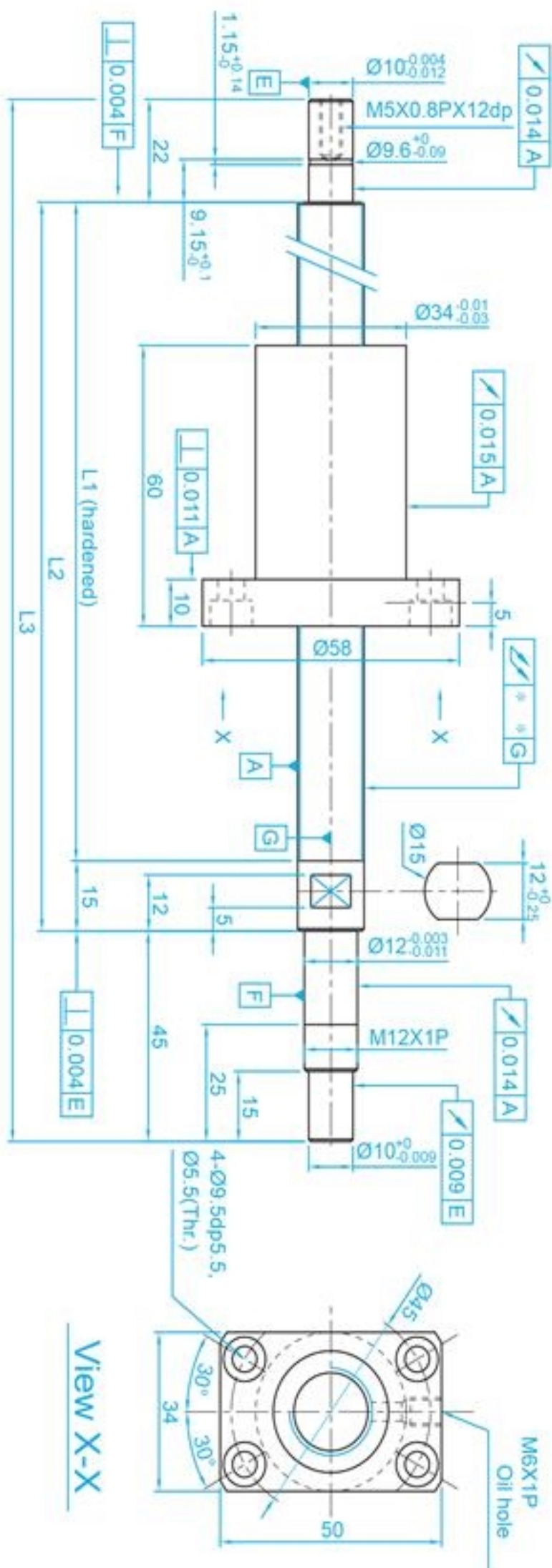

BCD	15.5
Ball Dia (mm)	3.175
Lead (mm)	20
No. of Turns	1.8x1
Lead Angle	22.33°
Threading Direction	R
Spring Force (kg)	0.1~0.3
Preload (kgf)	38
Dynamic Load Rating Ca (kgf)	638
Static Load Rating Coa (kgf)	1266
Accuracy Grade	0.018

Travel Length (mm)	Model No.	Shaft Length(mm)			Slant of Axle Center
		L1	L2	L3	
100	XSVR01520A1DGC5-271-P1	189	204	271	0.025
150	XSVR01520A1DGC5-321-P1	239	254	321	0.035
200	XSVR01520A1DGC5-371-P1	289	304	371	0.035
250	XSVR01520A1DGC5-421-P1	339	354	421	0.040
300	XSVR01520A1DGC5-471-P1	389	404	471	0.040
350	XSVR01520A1DGC5-521-P1	439	454	521	0.050
400	XSVR01520A1DGC5-571-P1	489	504	571	0.050
450	XSVR01520A1DGC5-621-P1	539	554	621	0.050
500	XSVR01520A1DGC5-671-P1	589	604	671	0.065
550	XSVR01520A1DGC5-721-P1	639	654	721	0.065
600	XSVR01520A1DGC5-771-P1	689	704	771	0.065
700	XSVR01520A1DGC5-871-P1	789	804	871	0.085
800	XSVR01520A1DGC5-971-P1	889	904	971	0.085

Unit : mm

Ball Screw

XSVR02010-00 Series Specifications (Finish Shaft Ends)

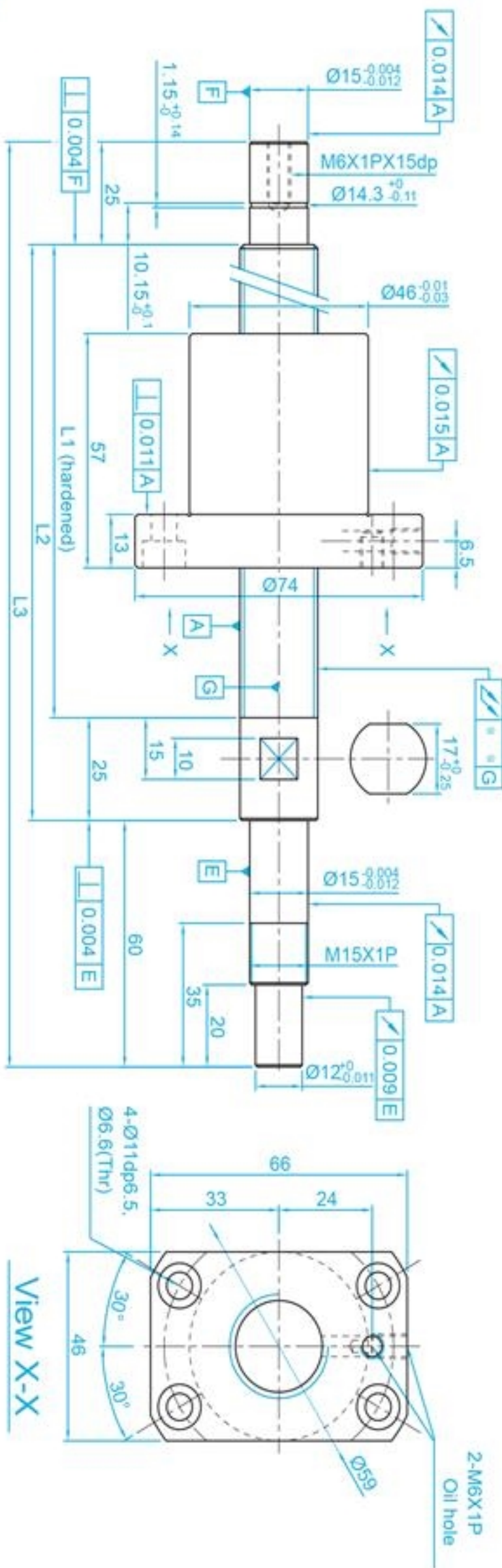

BCD	21.35
Ball Dia (mm)	3.969
Lead (mm)	10
No. of Turns	2.7x1
Lead Angle	8.48°
Threading Direction	R
Spring Force (kg)	0.1~0.3
Preload (kgf)	43
Dynamic Load Rating Ca (kgf)	1518
Static Load Rating Coa (kgf)	3398
Accuracy Grade	0.018

Travel Length (mm)	Model No.	Shaft Length(mm)			Slant of Axle Center
		L1	L2	L3	
200	XSVR02010B1DGC5-399-P1	289	314	399	0.035
300	XSVR02010B1DGC5-499-P1	389	414	499	0.040
400	XSVR02010B1DGC5-599-P1	489	514	599	0.050
500	XSVR02010B1DGC5-699-P1	589	614	699	0.065
600	XSVR02010B1DGC5-799-P1	689	714	799	0.065
700	XSVR02010B1DGC5-899-P1	789	814	899	0.085
800	XSVR02010B1DGC5-999-P1	889	914	999	0.085
900	XSVR02010B1DGC5-1099-P1	989	1014	1099	0.110
1000	XSVR02010B1DGC5-1199-P1	1089	1114	1199	0.110

Unit: mm

Ball Screw

SFU (DIN 69051 FORM B) Series Specifications

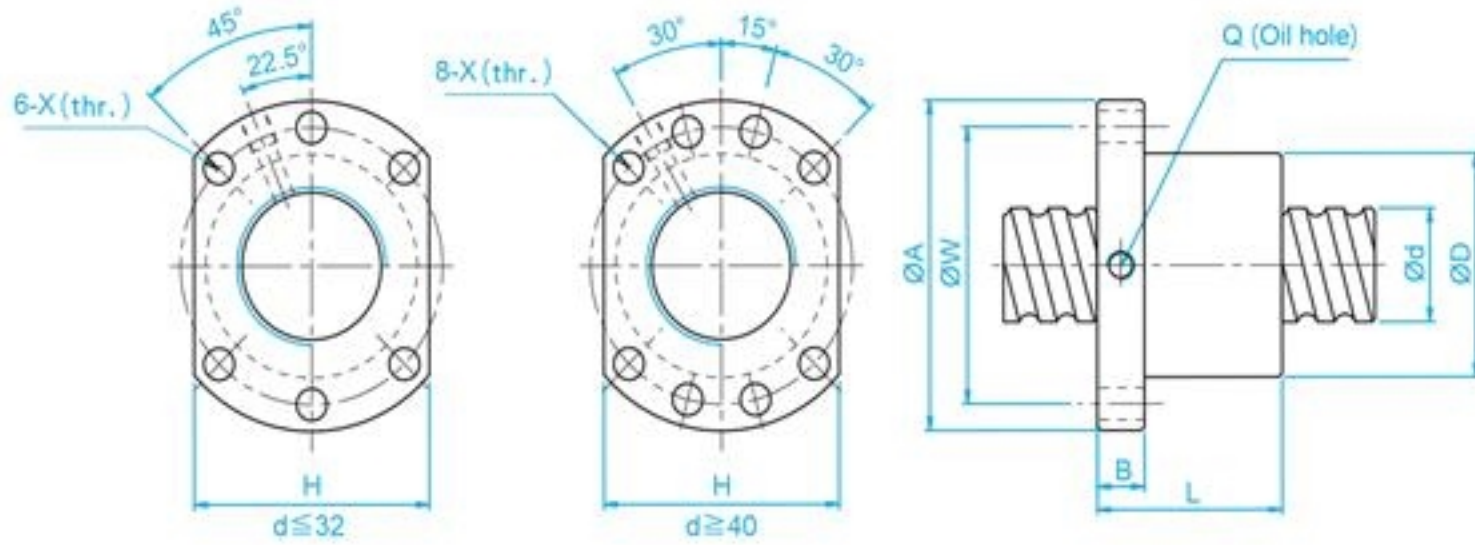

Unit: mm

Model No.	d	l	Da	Dimension									Ca (kgf)	Coa (kgf)	K kgf/ μ m
				D	A	B	L	W	H	X	Q	n			
SFU01204-4	12	4	2.5	24	40	10	40	32	30	4.5		1x4	902	1884	26
SFU01604-4	16	4	2.381	28	48	10	40	38	40	5.5	M6	1x4	973	2406	32
☆ SFU01605-4		5	3.175	28	48	10	50	38	40	5.5	M6	1x4	1380	3052	32
☆ SFU01610-3		10	3.175	28	48	10	57	38	40	5.5	M6	1x3	1103	2401	26
SFU02004-4	20	4	2.381	36	58	10	42	47	44	6.6	M6	1x4	1066	2987	38
☆ SFU02005-4		5	3.175	36	58	10	51	47	44	6.6	M6	1x4	1551	3875	39
SFU02504-4	25	4	2.381	40	62	10	42	51	48	6.6	M6	1x4	1180	3795	43
☆ SFU02505-4		5	3.175	40	62	10	51	51	48	6.6	M6	1x4	1724	4904	45
SFU02506-4		6	3.969	40	62	10	54	51	48	6.6	M6	1x4	2318	6057	47
SFU02508-4		8	4.762	40	62	10	63	51	48	6.6	M6	1x4	2963	7313	49
☆ SFU02510-4	10	4.762	40	62	12	85	51	48	6.6	M6	1x4	2954	7295	50	
SFU03204-4	32	4	2.381	50	80	12	44	65	62	9	M6	1x4	1296	4838	51
☆ SFU03205-4		5	3.175	50	80	12	52	65	62	9	M6	1x4	1922	6343	54
SFU03206-4		6	3.969	50	80	12	57	65	62	9	M6	1x4	2632	7979	57
SFU03208-4		8	4.762	50	80	12	65	65	62	9	M6	1x4	3387	9622	60
☆ SFU03210-4		10	6.35	50	80	12	90	65	62	9	M6	1x4	4805	12208	61
☆ SFU04005-4	40	5	3.175	63	93	14	55	78	70	9	M8	1x4	2110	7988	63
SFU04006-4		6	3.969	63	93	14	60	78	70	9	M6	1x4	2873	9913	66
SFU04008-4		8	4.762	63	93	14	67	78	70	9	M6	1x4	3712	11947	70
☆ SFU04010-4		10	6.35	63	93	14	93	78	70	9	M8	1x4	5399	15500	73
☆ SFU05010-4	50	10	6.35	75	110	16	93	93	85	11	M8	1x4	6004	19614	85
☆ SFU05020-4		20	7.144	75	110	16	138	93	85	11	M8	1x4	7142	22588	94
☆ SFU06310-4	63	10	6.35	90	125	18	98	108	95	11	M8	1x4	6719	25358	99
SFU06320-4		20	9.525	95	135	20	149	115	100	13.5	M8	1x4	11444	36653	112
☆ SFU08010-4	80	10	6.35	105	145	20	98	125	110	13.5	M8	1x4	7346	31953	109
SFU08020-4		20	9.525	125	165	25	154	145	130	13.5	M8	1x4	12911	47747	138
SFU10020-4	100	20	9.525	150	202	30	180	170	155	17.5	M8	1x4	14303	60698	162

※☆Left helix available※

Ball Screw

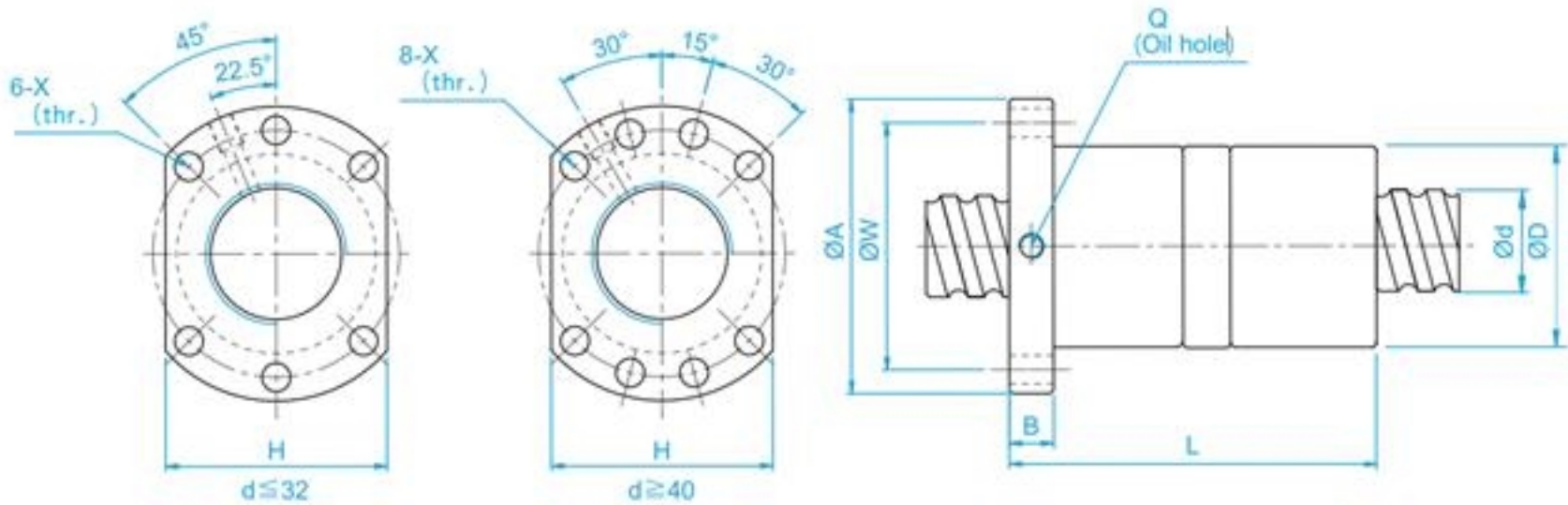

Model	Nominal diameter	Lead	Ball diameter	Nut size									Rated load (Kgf)		Rigidity (Kgf/D μm)
				D	A	B	L	W	H	X	Q	n	Ca	Coa	
DFU1604-4	16	4	2.381	28	48	10	80	38	40	5.5	M6	1x4	973	2406	43
DFU1605-4		5	3.175	28	48	10	100	38	40	5.5	M6	1x4	1380	3052	44
DFU1610-3		10	3.175	28	48	10	118	38	40	5.5	M6	1x3	1103	2401	35
DFU2004-4	20	4	2.381	36	58	10	80	47	44	6.6	M6	1x4	1066	2987	51
DFU2005-4		5	3.175	36	58	10	101	47	44	6.6	M6	1x4	1551	3875	53
DFU2504-4	25	4	2.381	40	62	10	80	51	48	6.6	M6	1x4	1180	3795	60
DFU2505-4		5	3.175	40	62	10	101	51	48	6.6	M6	1x4	1724	4904	62
DFU2506-4		6	3.969	40	62	10	105	51	48	6.6	M6	1x4	2318	6057	64
DFU2508-4		8	4.762	40	62	10	120	51	48	6.6	M6	1x4	2963	7313	67
DFU2510-4		10	4.762	40	62	12	145	51	48	6.6	M6	1x4	2954	7295	67
DFU3204-4	32	4	2.681	50	80	12	80	65	62	9	M6	1x4	1296	4838	71
DFU3205-4		5	3.175	50	80	12	102	65	62	9	M6	1x4	1922	6343	74
DFU3206-4		6	3.969	50	80	12	105	65	62	9	M6	1x4	2632	7979	78
DFU3208-4		8	4.762	50	80	12	122	65	62	9	M6	1x4	3387	9622	82
DFU3210-4		10	6.35	50	80	12	162	65	62	9	M6	1x4	4805	12208	82
DFU4005-4	40	5	3.175	63	93	14	105	78	70	9	M8	1x4	2110	7988	87
DFU4006-4		6	3.969	63	93	14	108	78	70	9	M6	1x4	2873	9913	91
DFU4008-4		8	4.762	63	93	14	132	78	70	9	M6	1x4	3712	11947	96
DFU4010-4		10	6.35	63	93	14	165	78	70	9	M8	1x4	5399	15500	99
DFU5010-4	50	10	6.35	75	110	16	171	93	85	11	M8	1x4	6004	19614	117
DFU5020-4		20	7.144	75	110	16	280	93	85	11	M8	1x4	7142	22588	126
DFU6310-4	63	10	6.35	90	125	18	182	108	95	11	M8	1x4	6719	25358	139
DFU6320-4		20	9.525	95	135	20	290	115	100	13.5	M8	1x4	11444	36653	152
DFU8010-4	80	10	6.35	105	145	20	182	125	110	13.5	M8	1x4	7346	31953	156
DFU8020-4		20	9.525	125	165	25	295	145	130	13.5	M8	1x4	12911	47747	187
DFU10020-4	100	20	9.525	150	202	30	340	170	155	17.5	M8	1x4	14303	60698	222

Ball Screw

SFS (DIN 69051 FORM B) Series Specifications

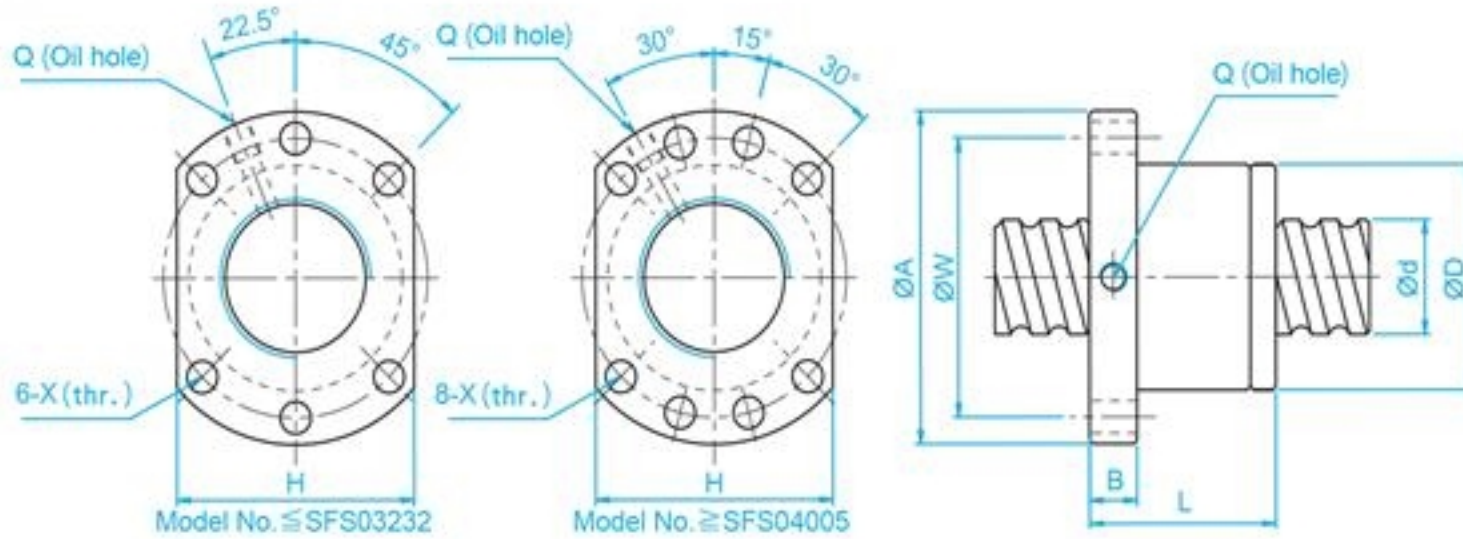

Unit: mm

Model No.	d	l	Da	Dimension									Ca (kgf)	Coa (kgf)	K kgf/μm
				D	A	B	L	W	H	X	Q	n			
SFS01205-2.8	12	5	2.5	24	40	10	31	32	30	4.5		2.8x1	661	1316	19
SFS01210-2.8		10	2.5	24	40	10	48.5	32	30	4.5		2.8x1	642	1287	19
SFS01605-3.8	15	5	2.778	28	48	10	38	38	40	5.5	M6	3.8x1	1112	2507	30
SFS01610-2.8		10	2.778	28	48	10	47	38	40	5.5	M6	2.8x1	839	1821	23
SFS01616-1.8		16	2.778	28	48	10	45	38	40	5.5	M6	1.8x1	552	1137	14
SFS01616-2.8		16	2.778	28	48	10	61	38	40	5.5	M6	2.8x1	808	1769	22
SFS01620-1.8		20	2.778	28	48	10	57	38	40	5.5	M6	1.8x1	554	1170	14
SFS02005-3.8	20	5	3.175	36	58	10	40	47	44	6.6	M6	3.8x1	1484	3681	37
SFS02010-3.8		10	3.175	36	58	10	60	47	44	6.6	M6	3.8x1	1516	3833	40
SFS02020-1.8		20	3.175	36	58	10	57	47	44	6.6	M6	1.8x1	764	1758	19
SFS02020-2.8		20	3.175	36	58	10	77	47	44	6.6	M6	2.8x1	1118	2734	29
SFS02505-3.8	25	5	3.175	40	62	10	40	51	48	6.6	M6	3.8x1	1650	4658	43
SFS02510-3.8		10	3.175	40	62	12	62	51	48	6.6	M6	3.8x1	1638	4633	45
SFS02525-1.8		25	3.175	40	62	12	70	51	48	6.6	M6	1.8x1	843	2199	22
SFS02525-2.8		25	3.175	40	62	12	95	51	48	6.6	M6	2.8x1	1232	3421	34
SFS03205-3.8	32	5	3.175	50	80	12	42	65	62	9	M6	3.8x1	1839	6026	51
SFS03210-3.8	31	10	3.969	50	80	13	62	65	62	9	M6	3.8x1	2460	7255	55
SFS03220-2.8		20	3.969	50	80	12	80	65	62	9	M6	2.8x1	1907	5482	43
SFS03232-1.8		32	3.969	50	80	13	84	65	62	9	M6	1.8x1	1257	3426	27
SFS03232-2.8		32	3.969	50	80	13	116	65	62	9	M6	2.8x1	1838	5329	42
SFS04005-3.8	40	5	3.175	63	93	15	45	78	70	9	M8	3.8x1	2018	7589	60
SFS04010-3.8	38	10	6.35	63	93	14	63	78	70	9	M8	3.8x1	5035	13943	67
SFS04020-2.8		20	6.35	63	93	14	82	78	70	9	M8	2.8x1	3959	10715	54
SFS04040-1.8		40	6.35	63	93	15	105	78	70	9	M8	1.8x1	2585	6648	34
SFS04040-2.8		40	6.35	63	93	15	145	78	70	9	M8	2.8x1	3780	10341	52
SFS05005-3.8	50	5	3.175	75	110	15	45	93	85	11	M8	3.8x1	2207	9542	68
SFS05010-3.8	48	10	6.35	75	110	18	68	93	85	11	M8	3.8x1	5638	17852	79
SFS05012-3.8		12	6.35	75	110	18	75	93	85	11	M8	3.8x1	5632	17836	81
SFS05020-3.8		20	6.35	75	110	18	108	93	85	11	M8	3.8x1	5749	18485	87
SFS05050-1.8		50	6.35	75	110	18	125	93	85	11	M8	1.8x1	2946	8749	42
SFS05050-2.8		50	6.35	75	110	18	175	93	85	11	M8	2.8x1	4308	13610	65

Ball Screw

SFI Series Specifications

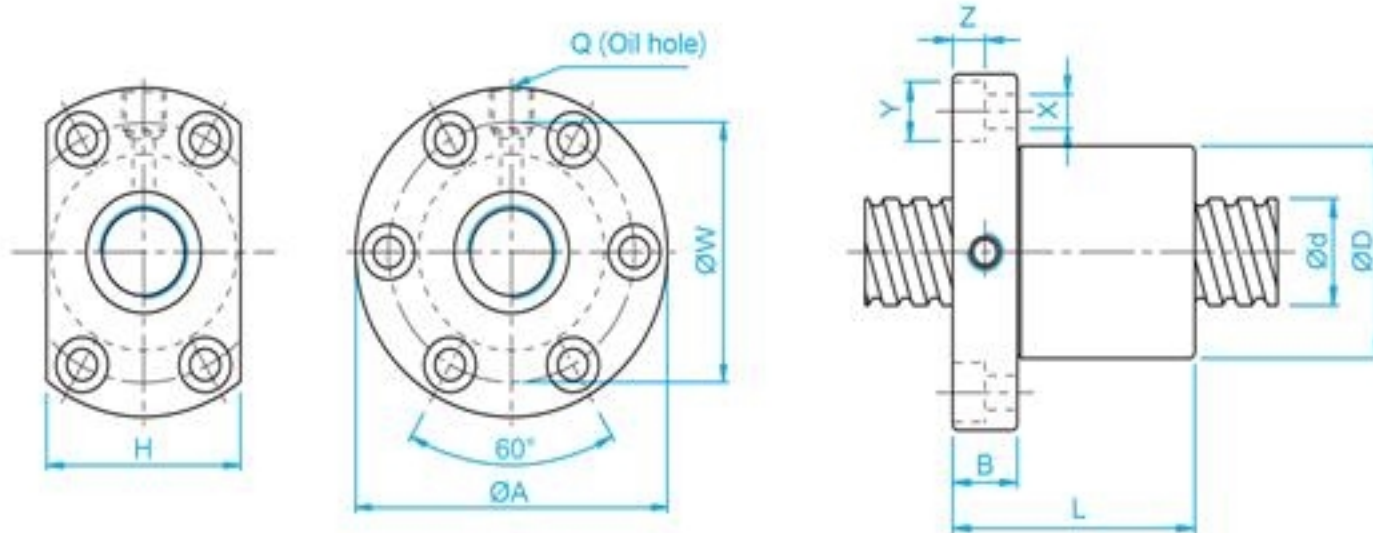

Unit: mm

Model No.	d	l	Da	Dimension											Ca (kgf)	Coa (kgf)	K kgf/μm
				D	A	B	L	W	H	X	Y	Z	Q	n			
SFI01604-4	16	4	2.381	30	49	10	45	39	34	4.5	8	4.5	M6	1x4	973	2406	32
☆ SFI01605-4		5	3.175	30	49	10	50	39	34	4.5	8	4.5	M6	1x4	1380	3052	33
☆ SFI01610-3		10	3.175	34	58	10	57	45	34	5.5	9.5	5.5	M6	1x3	1103	2401	27
SFI02004-4	20	4	2.381	34	57	11	46	45	40	5.5	9.5	5.5	M6	1x4	1066	2987	37
☆ SFI02005-4		5	3.175	34	57	11	51	45	40	5.5	9.5	5.5	M6	1x4	1551	3875	39
SFI0205T-4		5.08	3.175	34	57	11	51	45	40	5.5	9.5	5.5	M6	1x4	1550	3875	39
☆ SFI02504-4	25	4	2.381	40	63	11	46	51	46	5.5	9.5	5.5	M6	1x4	1180	3795	43
☆ SFI02505-4		5	3.175	40	63	11	51	51	46	5.5	9.5	5.5	M8	1x4	1724	4904	45
SFI0255T-4		5.08	3.175	40	63	11	51	51	46	5.5	9.5	5.5	M8	1x4	1724	4904	45
☆ SFI02510-4		10	4.762	46	72	12	85	58	52	6.5	11	6.5	M6	1x4	2954	7295	51
SFI03204-4	32	4	2.381	46	72	12	47	58	52	6.5	11	6.5	M6	1x4	1296	4838	49
☆ SFI03205-4		5	3.175	46	72	12	52	58	52	6.5	11	6.5	M8	1x4	1922	6343	52
☆ SFI03210-4		10	6.35	54	88	15	90	70	62	9	14	8.5	M8	1x4	4805	12208	62
☆ SFI04005-4	40	5	3.175	56	90	15	55	72	64	9	14	8.5	M8	1x4	2110	7988	59
☆ SFI04010-4		10	6.35	62	104	18	93	82	70	11	17.5	11	M8	1x4	5399	15500	72
☆ SFI05010-4	50	10	6.35	72	114	18	93	92	82	11	17.5	11	M8	1x4	6004	19614	83
☆ SFI06310-4	63	10	6.35	85	131	22	98	107	95	14	20	13	M8	1x4	6719	25358	95
SFI08010-4	80	10	6.35	105	150	22	98	127	115	14	20	13	M8	1x4	7346	31953	109

※ ☆ Left helix available ※

Ball Screw

SFV Series Specifications

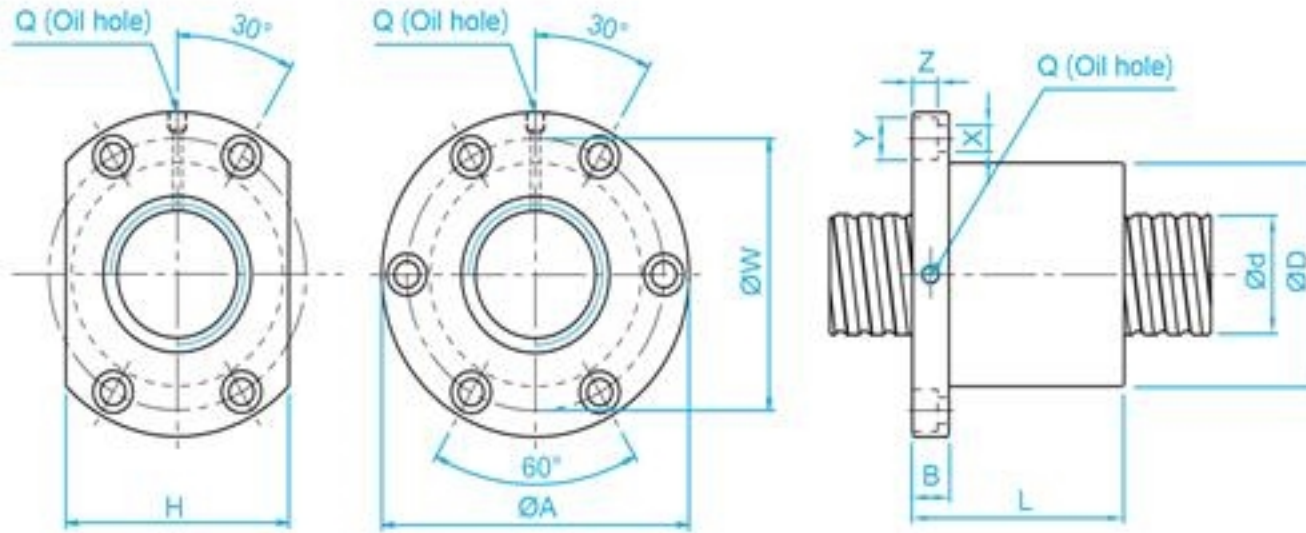

Unit: mm

Model No.	d	l	Da	Dimension											Ca (kgf)	Coa (kgf)	K kgf/ μ m
				D	A	B	L	W	H	X	Y	Z	Q	n			
SFV01205-2.8	12	5	2.5	30	50	10	42	40	32	4.5	8	4.5	M6	2.8x1	661	1316	19
SFV01210-2.7		10	2.5	30	50	10	53	40	32	4.5	8	4.5	M6	2.7x1	623	1241	18
SFV01510-2.7	15	10	3.175	34	58	10	57	45	34	5.5	9.5	5.5	M6	2.7x1	972	2020	23
SFV01604-3.8	16	4	2.381	34	57	11	45	45	34	5.5	9.5	5.5	M6	3.8x1	931	2285	31
SFV01605-4.8		5	3.175	40	63	11	58	51	42	5.5	9.5	5.5	M6	4.8x1	1614	3662	40
SFV01610-2.7		10	3.175	40	63	11	56	51	42	5.5	9.5	5.5	M6	2.7x1	1008	2161	24
SFV02004-4.8	20	4	2.381	40	60	10	50	50	40	4.5	8	4	M6	4.8x1	1247	3584	45
SFV02005-4.8		5	3.175	44	67	11	57	55	52	5.5	9.5	5.5	M6	4.8x1	1814	4650	47
SFV02010-2.7		10	3.969	46	74	13	57	59	46	6.6	11	6.5	M6	2.7x1	1518	3398	30
SFV02020-1.8		20	3.175	46	74	13	70	59	46	6.6	11	6.5	M6	1.8x1	764	1758	19
SFV02505-4.8	25	5	3.175	50	73	11	55	61	52	5.5	9.5	5.5	M8	4.8x1	2017	5884	56
SFV02506-4.8		6	3.969	53	76	11	62	64	58	5.5	9.5	5.5	M6	4.8x1	2711	7268	58
SFV02508-4.8		8	4.762	56	85	13	70	71	64	6.5	11	6.5	M6	4.8x1	3466	8776	61
SFV02510-2.7		10	6.35	68	102	15	70	84	82	9	14	8.5	M8	2.7x1	3040	6547	37
SFV02525-1.8		25	3.175	50	73	13	83	61	52	5.5	9.5	5.5	M8	1.8x1	843	2199	22
SFV03204-4.8	32	4	2.381	54	81	12	50	67	64	6.6	11	6.5	M6	4.8x1	1517	5806	62
SFV03205-4.8		5	3.175	58	85	12	56	71	64	6.6	11	6.5	M8	4.8x1	2249	7612	66
SFV03206-4.8		6	3.969	62	89	12	60	75	68	6.6	11	6.5	M8	4.8x1	3079	9575	70
SFV03208-4.8		8	4.762	66	100	15	75	82	76	9	14	8.5	M8	4.8x1	3962	11547	74
SFV03210-4.8		10	6.35	74	108	15	96	90	82	9	14	9	M8	4.8x1	5620	14649	76
SFV03220-2.7		20	6.35	74	108	16	100	90	82	9	14	8.5	M8	2.7x1	3509	8644	46
SFV04005-4.8	40	5	3.175	67	101	15	59	83	72	9	14	8.5	M8	4.8x1	2468	9586	76
SFV04010-4.8		10	6.35	82	124	18	100	102	94	11	17.5	11	M8	4.8x1	6316	18600	90
SFV04020-2.7		20	6.35	82	124	18	100	102	90	11	17.5	11	M8	2.7x1	3935	10893	56
SFV05005-4.8	50	5	3.175	80	114	15	60	96	82	9	14	8.5	M8	4.8x1	2698	12053	87
SFV05010-4.8		10	6.35	93	135	16	93	113	98	11	17.5	11	M8	4.8x1	7023	23537	106
SFV05020-2.7		20	9.525	105	152	28	121	128	110	14	20	13	M8	2.7x1	7336	19700	68
SFV06310-4.8	63	10	6.35	108	154	22	105	130	110	14	20	13	M8	4.8x1	7860	30430	126
SFV06320-2.7		20	9.525	122	180	28	120	150	130	18	26	17.5	M8	2.7x1	8162	24741	80
SFV08010-4.8	80	10	6.35	130	176	22	105	152	132	14	20	13	M8	4.8x1	8593	38344	145
SFV08020-4.8		20	9.525	143	204	28	180	172	148	18	26	18	M8	4.8x1	15103	57296	168
SFV08020-7.6		20	9.525	143	204	28	240	172	148	18	26	18	M8	3.8x2	22423	90719	260

Ball Screw

SFY Series Specifications

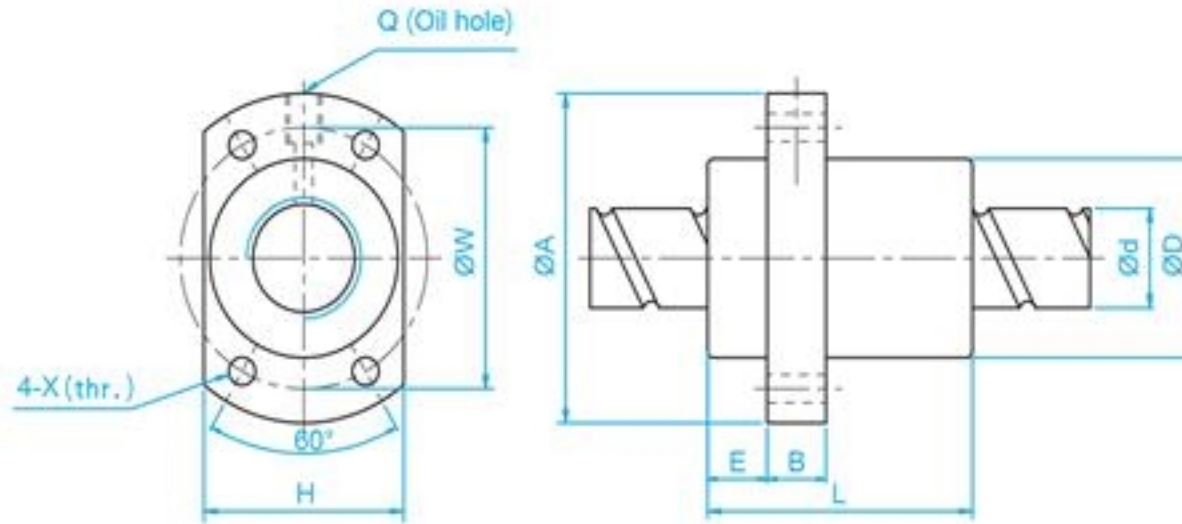

Unit: mm

Large Lead Model No.	d	l	Da	Dimension										Ca (kgf)	Coa (kgf)	K kgf/ µm
				D	A	E	B	L	W	H	X	Q	n			
SFY01616-3.6	16	16	2.778	32	53	10.1	10	45	42	34	4.5	M6	1.8x2	1073	2551	31
SFY01616-5.6		16	2.778	32	53	10.1	10	61	42	34	4.5	M6	2.8x2	1568	3968	47
SFY02020-3.6	20	20	3.175	39	62	13	10	52	50	41	5.5	M6	1.8x2	1387	3515	37
SFY02020-5.6		20	3.175	39	62	13	10	72	50	41	5.5	M6	2.8x2	2029	5468	56
SFY02525-3.6	25	25	3.969	47	74	15	12	64	60	49	6.6	M6	1.8x2	2074	5494	45
SFY02525-5.6		25	3.969	47	74	15	12	89	60	49	6.6	M6	2.8x2	3032	8546	69
SFY03232-3.6	32	32	4.762	58	92	17	12	78	74	60	9	M6	1.8x2	3021	8690	58
SFY03232-5.6		32	4.762	58	92	17	12	110	74	60	9	M6	2.8x2	4417	13517	88
SFY04040-3.6	40	40	6.35	73	114	19.5	15	99	93	75	11	M6	1.8x2	4831	14062	70
SFY04040-5.6		40	6.35	73	114	19.5	15	139	93	75	11	M6	2.8x2	7065	21874	106
SFY05050-3.6	50	50	7.938	90	135	21.5	20	117	112	92	14	M6	1.8x2	7220	21974	86
SFY05050-5.6		50	7.938	90	135	21.5	20	167	112	92	14	M6	2.8x2	10558	34182	131
Twin Lead Model No.	d	l	Da	Dimension										Ca (kgf)	Coa (kgf)	K kgf/ µm
				D	A	E	B	L	W	H	X	Q	n			
SFY01632-1.6	16	32	2.778	32	53	10.1	10	42.5	42	34	4.5	M6	0.8x2	493	1116	11
SFY01632-3.6		32	2.778	32	53	10.1	10	74.5	42	34	4.5	M6	1.8x2	989	2511	23
SFY02040-1.6	20	40	3.175	39	62	13	10	48	50	41	5.5	M6	0.8x2	653	1597	15
SFY02040-3.6		40	3.175	39	62	13	10	88	50	41	5.5	M6	1.8x2	1311	3592	30
SFY02550-1.6	25	50	3.969	47	74	15	12	58	60	49	6.6	M6	0.8x2	976	2495	19
SFY02550-3.6		50	3.969	47	74	15	12	108	60	49	6.6	M6	1.8x2	1960	5614	32
SFY03264-1.6	32	64	4.762	58	92	17	12	71	74	60	9	M6	0.8x2	1374	3571	22
SFY03264-3.6		64	4.762	58	92	17	12	135	74	60	9	M6	1.8x2	2759	8441	46
SFY04080-1.6	40	80	6.35	73	114	19.5	15	90	93	75	11	M6	0.8x2	2273	6387	29
SFY04080-3.6		80	6.35	73	114	19.5	15	170	93	75	11	M6	1.8x2	4566	14370	50
SFY050100-1.6	50	100	7.938	90	135	21.5	20	111	112	92	14	M6	0.8x2	3398	9980	35
SFY050100-3.6		100	7.938	90	135	21.5	20	211	112	92	14	M6	1.8x2	6824	22455	72

Ball Screw

DFV Series Specifications

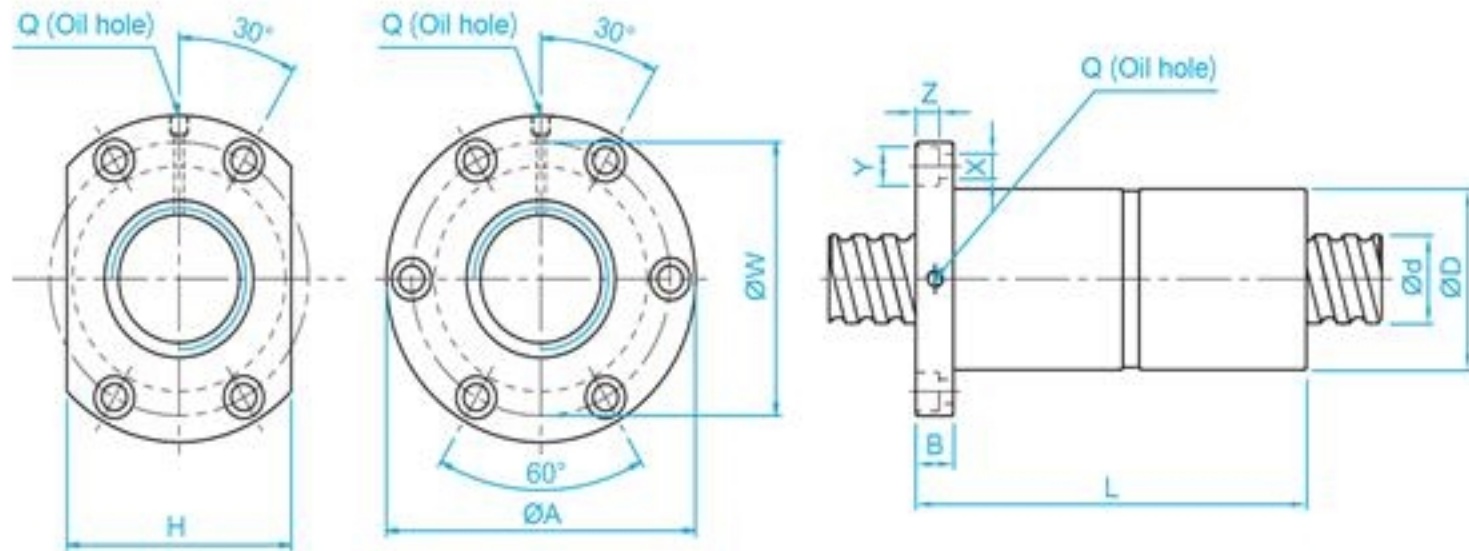

Unit: mm

Model No.	d	l	Da	Dimension											Ca (kgf)	Coa (kgf)	K (kgf/μm)
				D	A	B	L	W	H	X	Y	Z	Q	n			
DFV01510-2.7	15	10	3.175	34	58	10	107	45	34	5.5	9.5	5.5	M6	2.7x1	972	2020	30
DFV01604-3.8	16	4	2.381	34	57	11	89	45	34	5.5	9.5	5.5	M6	3.8x1	931	2285	42
DFV01605-4.8		5	3.175	40	63	11	113	51	42	5.5	9.5	5.5	M6	4.8x1	1614	3662	53
DFV01610-2.7		10	3.175	40	63	11	106	51	42	5.5	9.5	5.5	M6	2.7x1	1008	2161	32
DFV02004-4.8	20	4	2.381	40	60	10	94	50	40	4.5	8	4	M6	4.8x1	1247	3584	61
DFV02005-4.8		5	3.175	44	67	11	112	55	52	5.5	9.5	5.5	M6	4.8x1	1814	4650	63
DFV02010-2.7		10	3.969	46	74	13	117	59	46	6.6	11	6.5	M6	2.7x1	1518	3398	40
DFV02505-4.8	25	5	3.175	50	73	11	105	61	52	5.5	9.5	5.5	M8	4.8x1	2017	5884	75
DFV02506-4.8		6	3.969	53	76	11	116	64	58	5.5	9.5	5.5	M6	4.8x1	2711	7268	78
DFV02508-4.8		8	4.762	56	85	13	134	71	64	6.5	11	6.5	M6	4.8x1	3466	8776	82
DFV02510-2.7		10	6.35	68	102	15	130	84	82	9	14	8.5	M8	2.7x1	3040	6547	49
DFV03204-4.8	32	4	2.381	54	81	12	94	67	64	6.6	11	6.5	M6	4.8x1	1517	5806	85
DFV03205-4.8		5	3.175	58	85	12	106	71	64	6.6	11	6.5	M8	4.8x1	2249	7612	90
DFV03206-4.8		6	3.969	62	89	12	114	75	68	6.6	11	6.5	M8	4.8x1	3079	9575	95
DFV03208-4.8		8	4.762	66	100	15	139	82	76	9	14	8.5	M8	4.8x1	3962	11547	100
DFV03210-4.8		10	6.35	74	108	15	186	90	82	9	14	9	M8	4.8x1	5620	14649	101
DFV03220-2.7		20	6.35	74	108	16	200	90	82	9	14	8.5	M8	2.7x1	3509	8644	61
DFV04005-4.8	40	5	3.175	67	101	15	109	83	72	9	14	8.5	M8	4.8x1	2468	9586	105
DFV04010-4.8		10	6.35	82	124	18	188	102	94	11	17.5	11	M8	4.8x1	6316	18600	121
DFV04020-2.7		20	6.35	82	124	18	200	102	90	11	17.5	11	M8	2.7x1	3935	10893	74
DFV05005-4.8	50	5	3.175	80	114	15	115	96	82	9	14	8.5	M8	4.8x1	2698	12053	122
DFV05010-4.8		10	6.35	93	135	16	173	113	98	11	17.5	11	M8	4.8x1	7023	23537	144
DFV05020-2.7		20	9.525	105	152	28	221	128	110	14	20	13	M8	2.7x1	7336	19700	90
DFV06310-4.8	63	10	6.35	108	154	22	195	130	110	14	20	13	M8	4.8x1	7860	30430	172
DFV06320-2.7		20	9.525	122	180	28	220	150	130	18	26	17.5	M8	2.7x1	8162	24741	107
DFV08010-4.8	80	10	6.35	130	176	22	195	152	132	14	20	13	M8	4.8x1	8593	38344	201
DFV08020-4.8		20	9.525	143	204	28	340	172	148	18	26	18	M8	4.8x1	15103	57296	226
DFV08020-7.6		20	9.525	143	204	28	460	172	148	18	26	18	M8	3.8x2	22423	90719	351

Ball Screw

DFS (DIN 69051 FORM B) Series Specifications

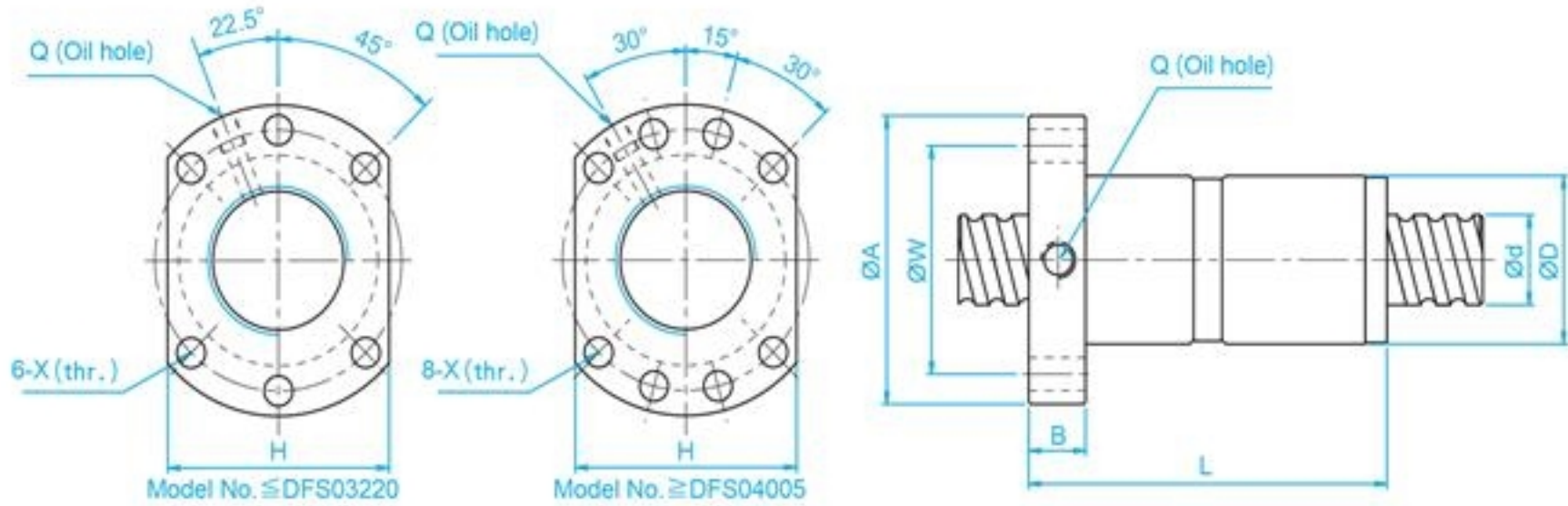

Unit: mm

Model No.	d	l	Da	Dimension									Ca (kgf)	Coa (kgf)	K kgf/μm
				D	A	B	L	W	H	X	Q	n			
DFS01605-3.8	15	5	2.778	28	48	10	73	38	40	5.5	M6	3.8x1	1112	2507	41
DFS01610-2.8		10	2.778	28	48	10	97	38	40	5.5	M6	2.8x1	839	1821	31
DFS02005-3.8	20	5	3.175	36	58	10	75	47	44	6.6	M6	3.8x1	1484	3681	50
DFS02010-3.8		10	3.175	36	58	10	120	47	44	6.6	M6	3.8x1	1516	3833	53
DFS02505-3.8	25	5	3.175	40	62	10	75	51	48	6.6	M6	3.8x1	1650	4658	59
DFS02510-3.8		10	3.175	40	62	12	122	51	48	6.6	M6	3.8x1	1638	4633	61
DFS03205-3.8	32	5	3.175	50	80	12	82	65	62	9	M6	3.8x1	1839	6026	71
DFS03210-3.8	31	10	3.969	50	80	13	122	65	62	9	M6	3.8x1	2460	7255	75
DFS03220-2.8		20	3.969	50	80	12	160	65	62	9	M6	2.8x1	1907	5482	58
DFS04005-3.8	40	5	3.175	63	93	15	85	78	70	9	M8	3.8x1	2018	7589	83
DFS04010-3.8	38	10	6.35	63	93	14	123	78	70	9	M8	3.8x1	5035	13943	91
DFS04020-2.8		20	6.35	63	93	14	162	78	70	9	M8	2.8x1	3959	10715	73
DFS05005-3.8	50	5	3.175	75	110	15	85	93	85	11	M8	3.8x1	2207	9542	96
DFS05010-3.8	48	10	6.35	75	110	18	138	93	85	11	M8	3.8x1	5638	17852	109
DFS05012-3.8		12	6.35	75	110	18	147	93	85	11	M8	3.8x1	5632	17836	110
DFS05020-3.8		20	6.35	75	110	18	218	93	85	11	M8	3.8x1	5749	18485	116