



Auto Linear Motion

Miniature Ball screw



ALM Intelligent Technology (Suzhou) Co., Limited

Add: No 1998 Jinfeng south road, Wuzhong district, Suzhou city, China

E-mail: sales@autolinearmotion.com

Tel: +8618962406535

Web: www.autolinearmotion.com

Miniature Ball screw

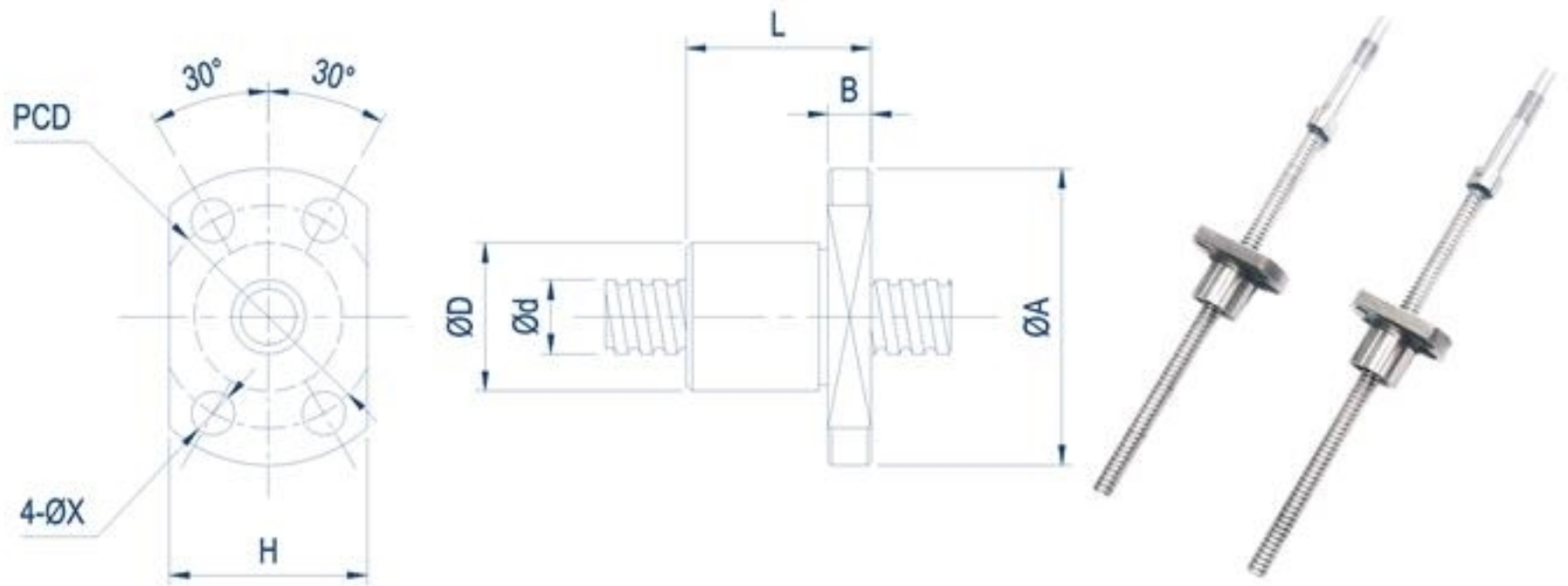

Code	d	P	Dw	n	Ca	Coa	K	Nut Dimension									
								D	A	B	L	PCD	H	X	Y	Z	Q
ASF0401	4	1	0.8	2	40	51	2.8	10	20	3	12	15	14	2.9	/	/	/
ASF0601	6	1	0.8	2	66	111	6.8	12	24	3.5	15	18	16	3.4	/	/	/
ASF0602	6	2	1.2	3	73	121	6.8	12	24	4	18	18	16	3.4	/	/	/
ASF0801	8	1	0.8	3	161	403	14	14	27	4	16	21	18	3.4	/	/	/
ASF0802	8	2	1.2	3	222	458	13	14	27	4	16	21	18	3.4	/	/	/
ASF0802.5	8	2.5	1.2	3	221	457	13	16	29	4	26	23	20	3.4	/	/	/
ASF1002	10	2	1.588	3	243	569	15	18	35	5	28	27	22	4.5	/	/	/
ASF1003	10	3	2.0	3	245	570	15	20	35	5	30	27	22	4.5	/	/	/
ASF1004	10	4	2.381	3	468	905	17	22	46	10	38	36	28	4.5	/	/	/
ASF1201	12	1	0.8	3	173	317	15	20	37	5	28	29	24	4.5	/	/	/
ASF1202	12	2	1.588	3	334	902	22	20	37	5	28	29	24	4.5	/	/	/
ASF1202.5	12	2.5	1.588	3	355	981	22	20	37	5	28	29	24	4.5	/	/	/
ASF1203	12	3	1.6	3	365	990	22	20	37	5	28	29	24	4.5	/	/	/
ASF1205	12	5	2.0	3	619	883	22	22	40	8	38	32	24	4.5	/	/	/
ASF1402	14	2	1.588	3	354	1053	24	21	40	6	23	31	26	5.5	/	/	/
ASF1602	16	2	1.588	3	373	1200	26	25	43	10	40	35	29	5.5	/	/	/
ASF1602.5	16	2.5	1.588	3	400	1210	26	25	43	10	40	35	29	5.5	/	/	/
ASF1603	16	3	2.0	3	530	1380	26	25	43	10	40	35	29	5.5	/	/	/

Not: the size and shape of the nut can be made as per customers' requirement.

P: lead . Dw: ball diameter n: number of ball recirculation. K: stiffness (Kgf/ μ m).
Ca: basic dynamic rating load (Kgf). Coa: basic static rating load (Kgf).

Miniature Ball screw

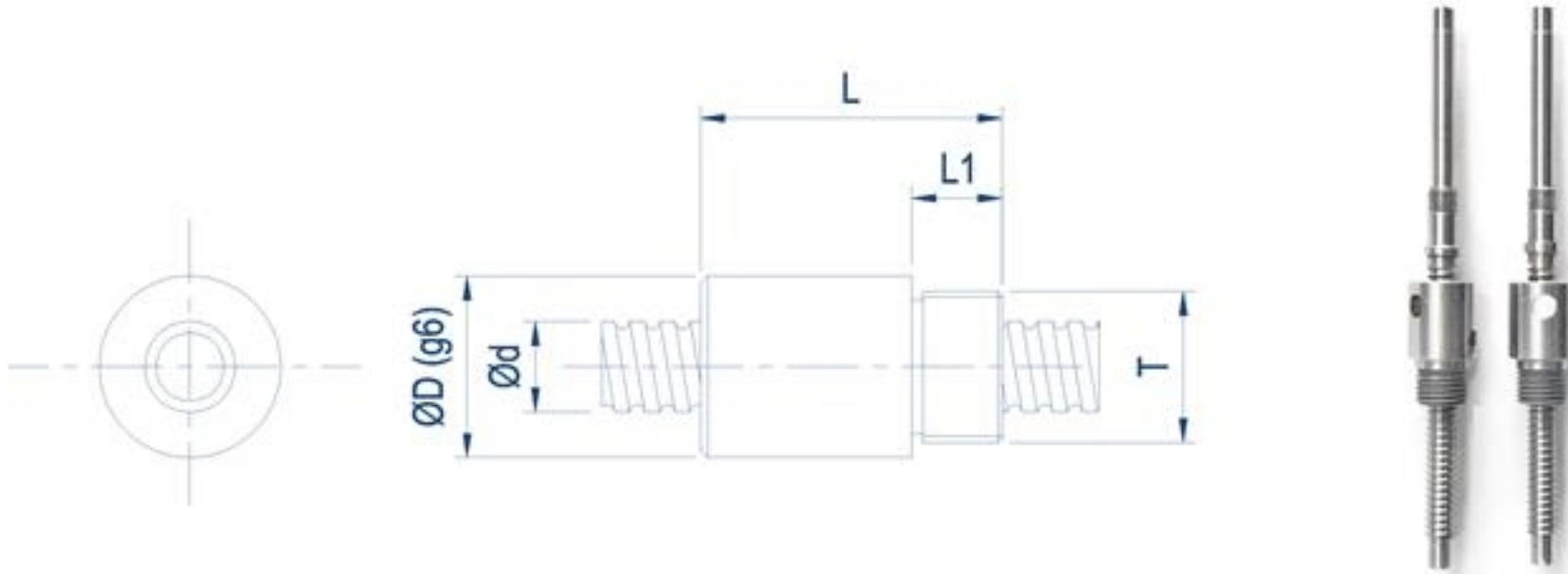

Code	d	P	Dw	n	Ca	Coa	K	Nut Dimension			
								D	L	L1	T
ASA0401	4	1	0.8	2	40	51	2.8	10	15	5	M8x0.75
ASA0601	6	1	0.8	2	66	111	6.8	12	15	5	M10x1
ASA0602	6	2	1.2	3	73	121	6.8	12	20	6	M10x1
ASA0801	8	1	0.8	3	135	225	7.4	16	22	8	M14x1
ASA0802	8	2	1.2	3	135	225	7.4	16	27	8	M14x1
ASA0802.5	8	2.5	1.2	3	177	278	7.4	16	29	8	M14x1
ASA1002	10	2	1.588	3	185	305	9.0	18	28	7	M16x1
ASA1003	10	3	2.0	3	185	305	9.0	18	28	7	M16x1
ASA1004	10	4	2.381	3	395	590	9.0	26	34	10	M16x1
ASA1201	12	1	0.8	3	173	317	11	20	39	10	M18x1
ASA1202	12	2	1.588	3	173	317	11	20	28	10	M18x1
ASA1202.5	12	2.5	1.588	3	173	317	11	20	28	10	M18x1
ASA1203	12	3	1.6	3	173	317	11	20	33	10	M18x1
ASA1205	12	5	2.0	3	619	883	17	24	38	10	M20x1
ASA1402	14	2	1.588	3	287	633	12	24	38	10	M20x1
ASA1602	16	2	1.588	3	253	671	12	25	44	10	M22x1
ASA1602.5	16	2.5	1.588	3	253	671	12	25	44	10	M22x1
ASA1603	16	3	2.0	3	253	671	12	25	44	10	M22x1

Not: the size and shape of the nut can be made as per customers' requirement.

P: lead . Dw: ball diameter n: number of ball recirculation. K: stiffness (Kgf/μm).
Ca: basic dynamic rating load (Kgf). Coa: basic static rating load (Kgf).

Miniature Ball screw

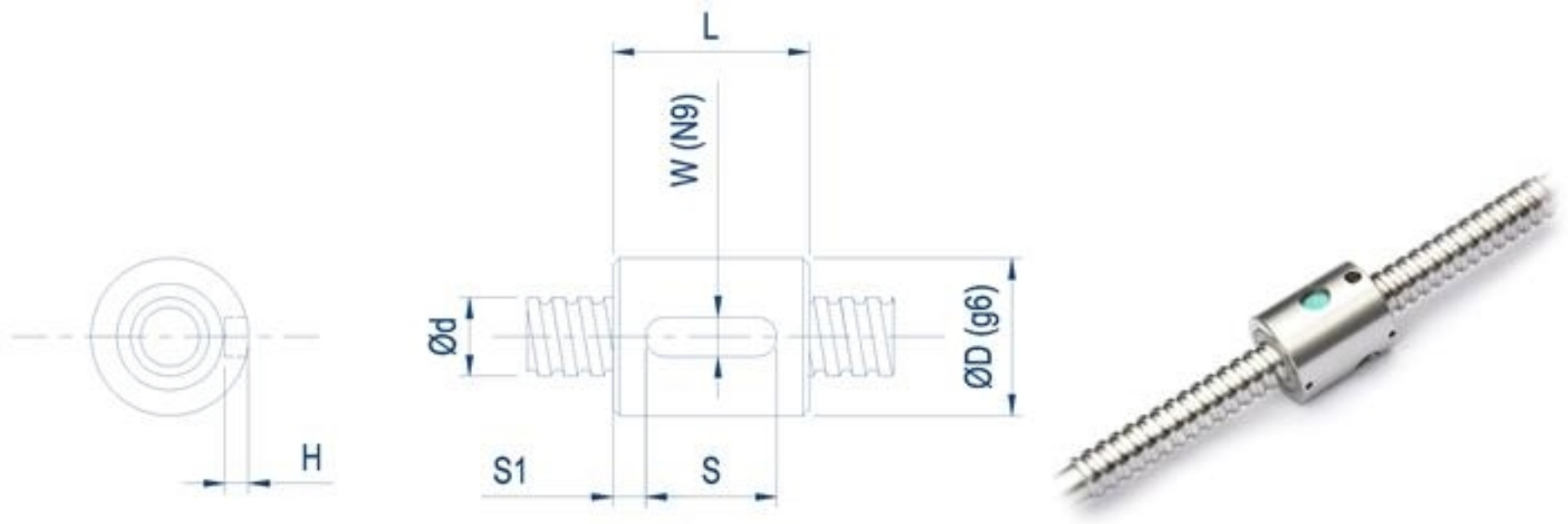

Code	d	P	Dw	n	Ca	Coa	K	Nut Dimension	
								D	L
ASC0401	4	1	0.8	2	40	51	2.8	10	12
ASC0601	6	1	0.8	2	66	111	6.8	12	15
ASC0602	6	2	1.2	3	73	121	6.8	12	15
ASC0801	8	1	0.8	3	135	225	7.4	14	16
ASC0802	8	2	1.2	3	135	225	7.4	14	16
ASC0802.5	8	2.5	1.2	3	177	278	7.4	16	26
ASC1002	10	2	1.588	3	185	305	9.0	18	28
ASC1003	10	3	2.0	3	185	305	9.0	18	28
ASC1004	10	4	2.381	3	395	590	9.0	26	34
ASC1201	12	1	0.8	3	173	317	11	20	28
ASC1202	12	2	1.588	3	173	317	11	20	28
ASC1202.5	12	2.5	1.588	3	173	317	11	20	28
ASC1203	12	3	1.6	3	173	317	11	20	28
ASC1205	12	5	2.0	3	619	883	17	22	38
ASC1402	14	2	1.588	3	287	633	12	21	23
ASC1602	16	2	1.588	3	253	670	12	25	40
ASC1602.5	16	2.5	1.588	3	253	670	12	25	40
ASC1603	16	3	2.0	3	253	670	12	25	40

Not: the size and shape of the nut can be made as per customers' requirement.

P: lead . Dw: ball diameter n: number of ball recirculation. K: stiffness (Kgf/ μ m).
Ca: basic dynamic rating load (Kgf). Coa: basic static rating load (Kgf).

Miniature Ball screw

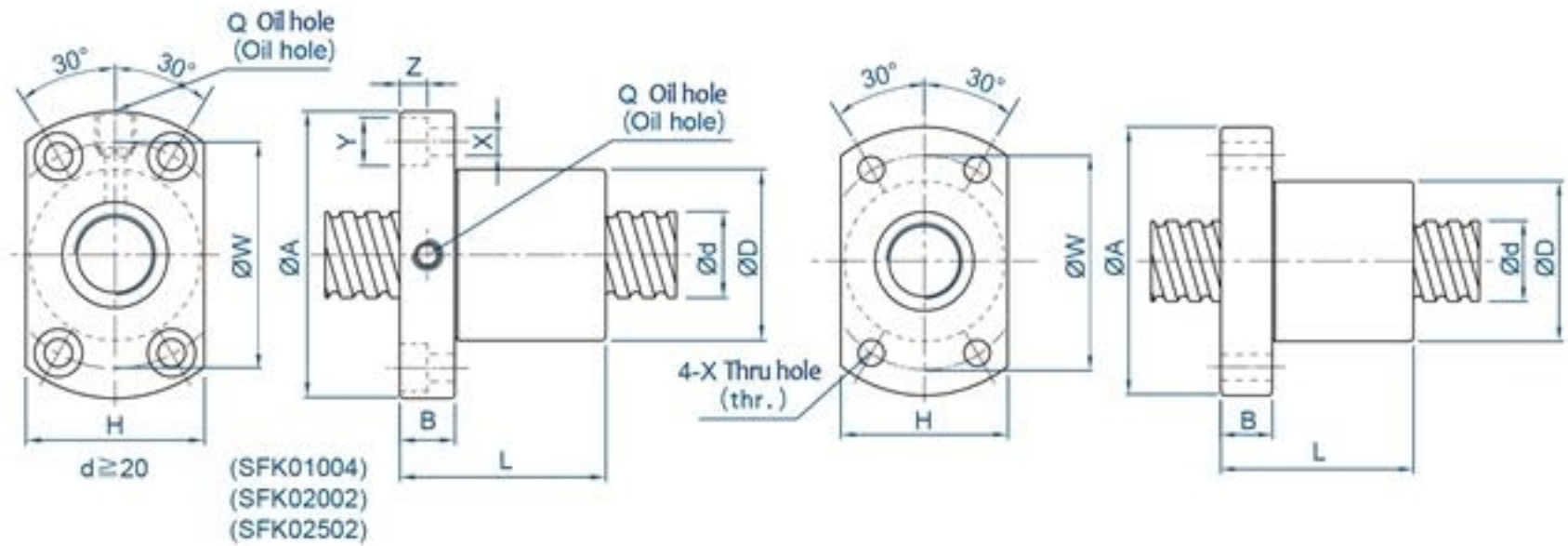

Code	d	P	Dw	Nut Dimension											(Kgf)		(Kg f / μ m)
				D	A	B	L	W	H	X	Y	Z	Q	n	Ca	Coa	
SFK0401	4	1	0.8	10	20	3	12	15	14	2.9	-	-	-	1x2	64	97	5
SFK0601	6	1	0.8	12	24	3.5	15	18	16	3.4	-	-	-	1x3	111	224	9
SFK0801	8	1	0.8	14	27	4	16	21	18	3.4	-	-	-	1x4	161	403	14
SFK0802		2	1.2	14	27	4	16	21	18	3.4	-	-	-	1x3	222	458	13
SFK0802.5		2.5	1.2	16	29	4	26	23	20	3.4	-	-	-	1x3	221	457	13
SFK1002	10	2	1.2	18	35	5	28	27	22	4.5	-	-	-	1x3	243	569	15
SFK1004		4	2	26	46	10	34	36	28	4.5	8	4.5	M6	1x3	468	905	17
SFK1202	12	2	1.2	20	37	5	28	29	24	4.5	-	-	-	1x4	334	906	22
SFK1402	14	2	1.2	21	40	6	23	31	26	5.5	-	-	-	1x4	354	1053	24
SFK1602	16	2	1.2	25	43	10	40	35	29	5.5	-	-	M6	1x4	373	1200	26
SFK2002	20	2	1.2	50	80	15	55	65	68	6.5	10.5	6	M6	1x6	581	2284	48
SFK2502	25	2	1.2	50	80	13	43	65	68	6.5	10.5	6	M6	1x5	540	2381	46

Left hand thread are available for above items.

Code	d	P	Dw	Nut Dimension											(Kgf)		(Kg f / μ m)
				D	A	B	L	W	H	X	Y	Z	Q	n	Ca	Coa	
XSUR1204T3D-02	12	4	2.5	24	40	6	28	32	25	3.5	-	-	-	1x3	454	722	-
XSUR1205T3D-00		5	2.5	22	37	8	39	29	24	4.5	-	-	-	1x3	675	1316	17

Miniature Ball screw

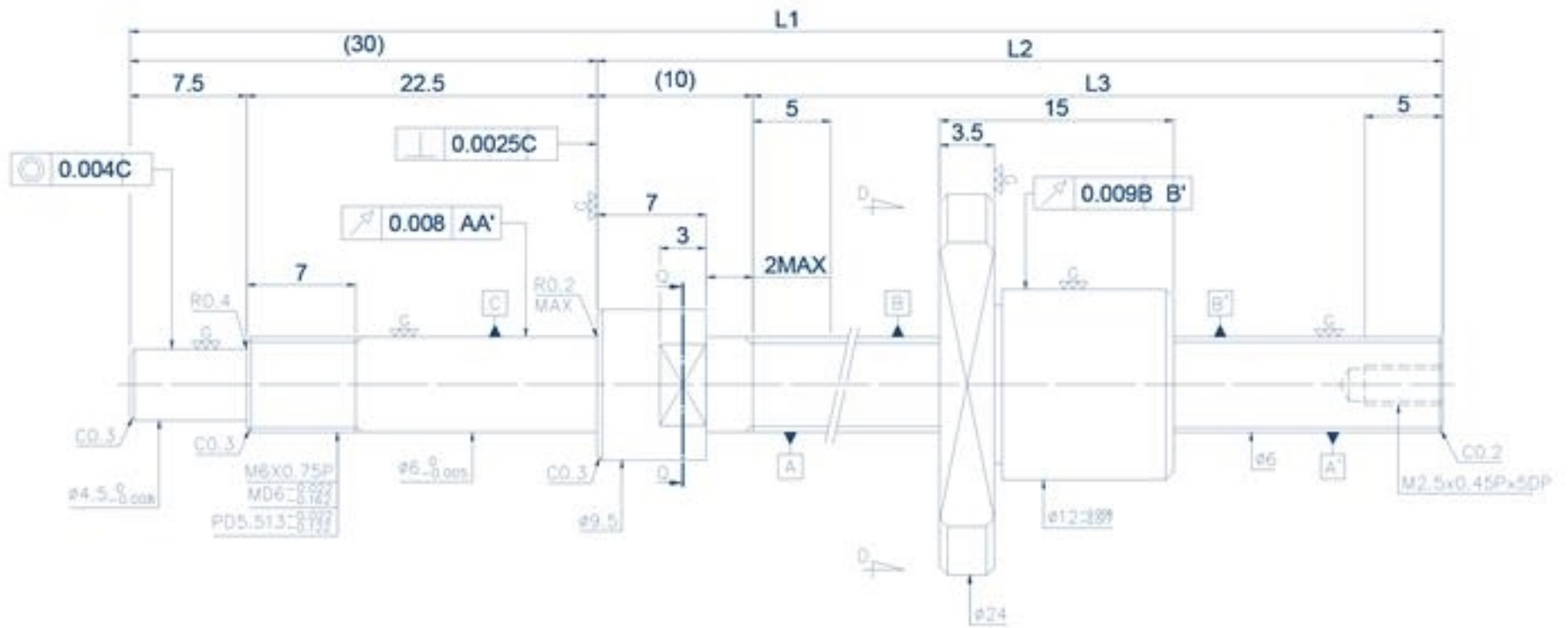

Ball Screw Specification

Thread direction	LH/RH	
Lead (mm)	1/2	
Lead angle	2.99°	
Section circle diameter (mm)	6.1	
Shaft section circle diameter (mm)	6.1	
Root diameter(mm)	5.261	
Ball Dia(mm)	Φ0.8/Φ1.2	
No of Circuit	1x3	
Basic dynamic rating load (kgf)	66/73	
Basic static rating load (kgf)	111/121	
Axial play(mm)	0	0.005 MAX
Preload torque	0.13 MAX	0.003 MAX

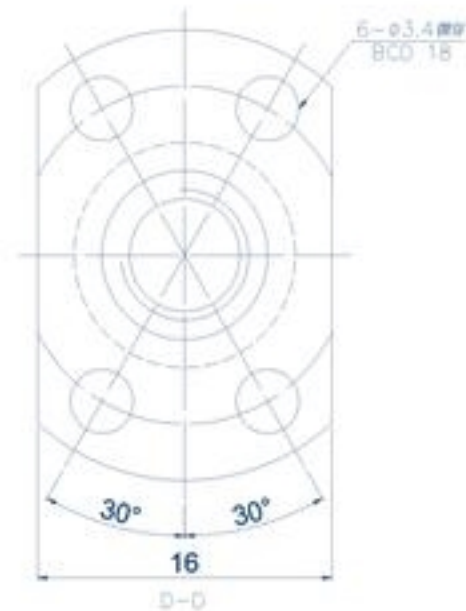

Stroke	Model No	L1	L2	L3	Accuracy grade
40	ASF0601/ASF0602-65x105	65	75	105	C3, C5
70	ASF0601/ASF0602-95x135	95	105	135	C3, C5
100	ASF0601/ASF0602-125x165	125	135	165	C3, C5

Miniature Ball screw

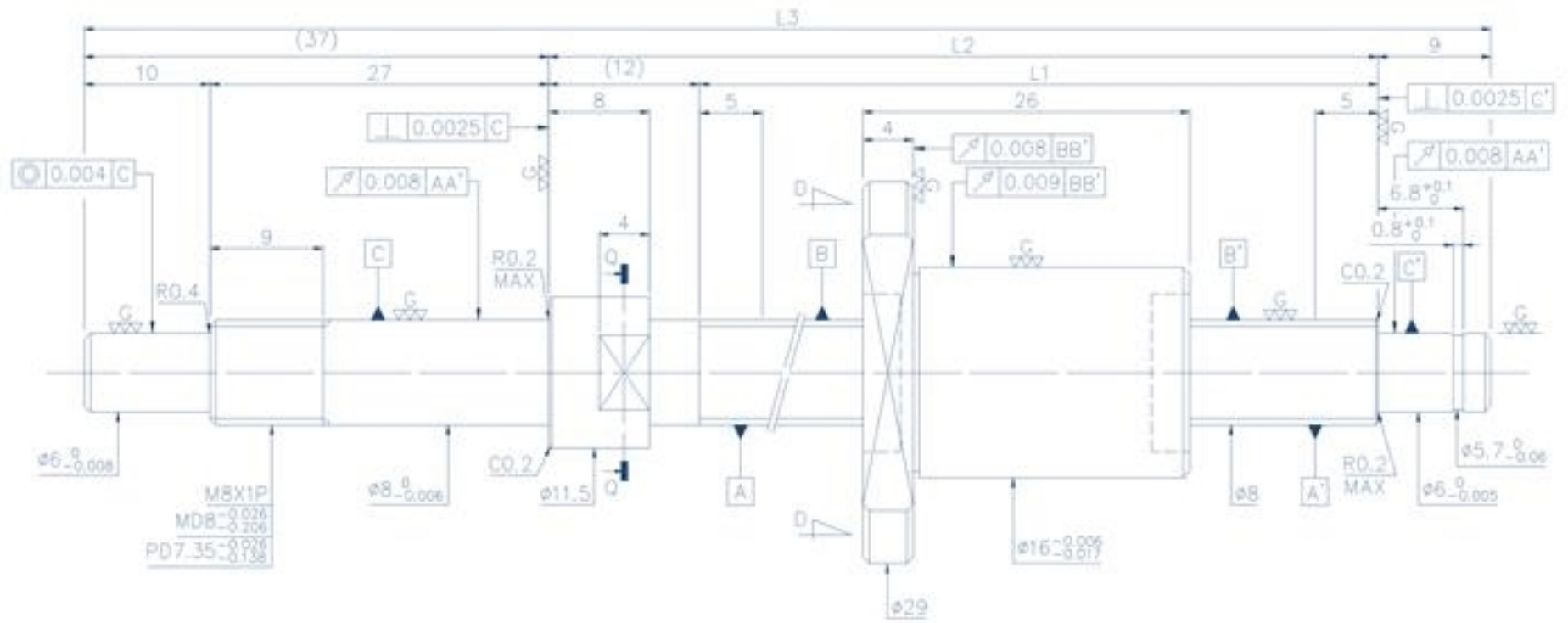

Ball Screw Specification		
Thread direction	LH/RH	
Lead (mm)	1/2	
Lead angle	4.44°	
Section circle diameter (mm)	8.2	
Shaft section circle diameter (mm)	8.2	
Root diameter(mm)	6.652	
Ball Dia(mm)	$\phi 0.8/\phi 1.2$	
No of Circuit	1x3	
Basic dynamic rating load (kgf)	161/222	
Basic static rating load (kgf)	403/458	
Axial play(mm)	0	0.005 MAX
Preload torque	0.20 MAX	0.003 MAX

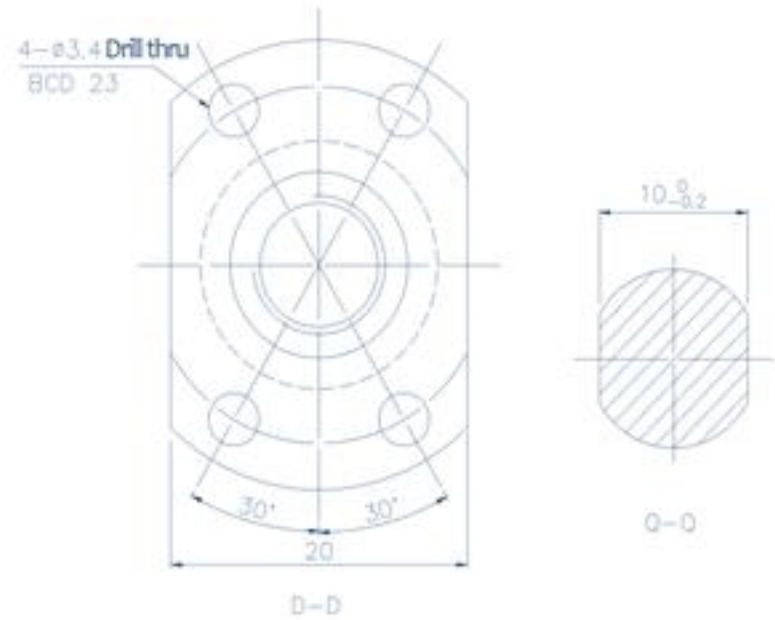

Stroke	Model No	L1	L2	L3	Accuracy grade
40	ASF0801/ASF0802-80x138	80	92	138	C3, C5
70	ASF0801/ASF0802-110x168	110	122	168	C3, C5
100	ASF0801/ASF0802-140x198	140	152	198	C3, C5
150	ASF0801/ASF0802-190x248	190	202	248	C3, C5

Miniature Ball screw

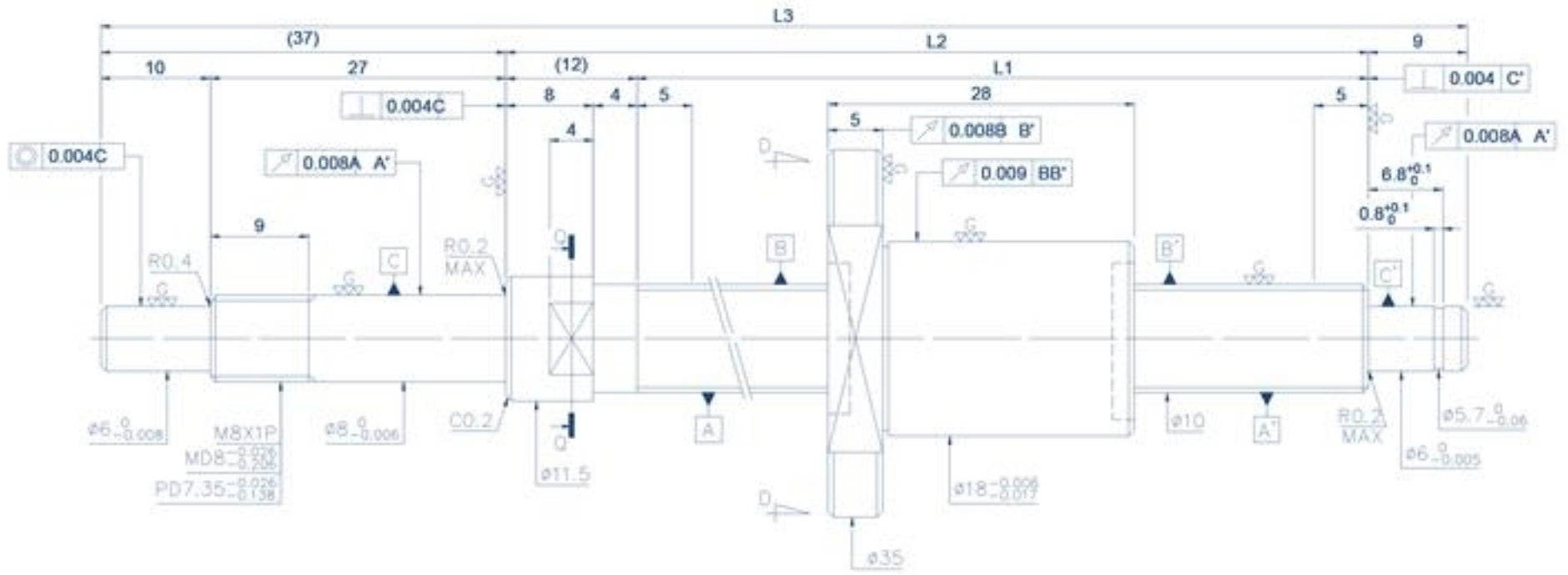

Ball Screw Specification		
Thread direction	LH/RH	
Lead (mm)	2	
Lead angle	3.57°	
Section circle diameter (mm)	10.2	
Shaft section circle diameter (mm)	10.2	
Root diameter(mm)	8.652	
Ball Dia(mm)	Φ1.588	
No of Circuit	1x3	
Basic dynamic rating load (kgf)	243	
Basic static rating load (kgf)	569	
Axial play(mm)	0	0.005 MAX
Preload torque	0.01-0.24	0.05 MAX

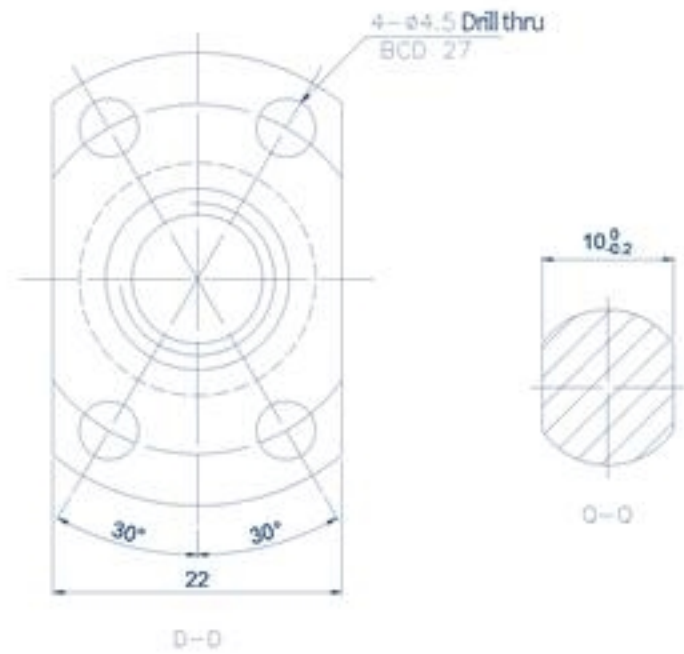

Stroke	Model No	L1	L2	L3	Accuracy grade
50	ASF1002-100x158	100	112	158	C3, C5
100	ASF1002-150x208	150	162	208	C3, C5
150	ASF1002-200x258	200	212	258	C3, C5
200	ASF1002-250x308	250	262	308	C3, C5

Miniature Ball screw

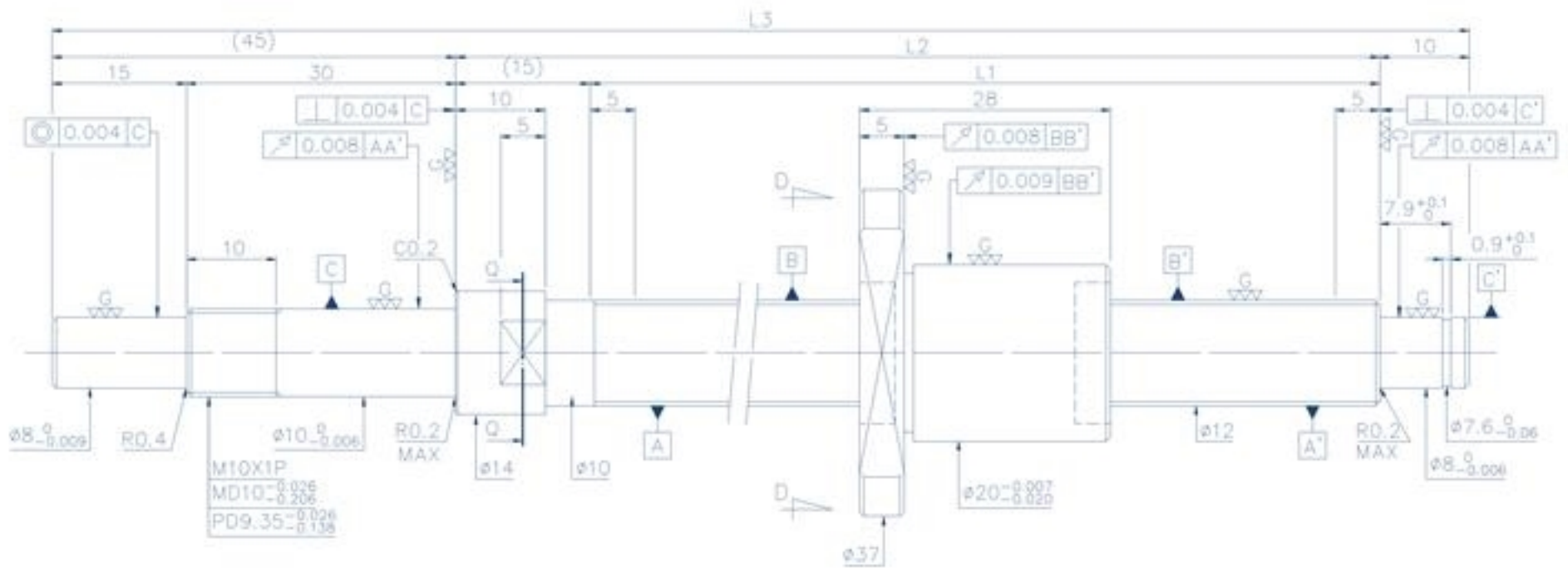

Ball Screw Specification		
Thread direction	LH/RH	
Lead (mm)	2	
Lead angle	2.99°	
Section circle diameter (mm)	12.2	
Shaft section circle diameter (mm)	12.2	
Root diameter(mm)	10.625	
Ball Dia(mm)	Φ1.588	
No of Circuit	1x3	
Basic dynamic rating load (kgf)	334	
Basic static rating load (kgf)	802	
Axial play(mm)	0	0.005 MAX
Preload torque	0.04-0.35	0.2 MAX

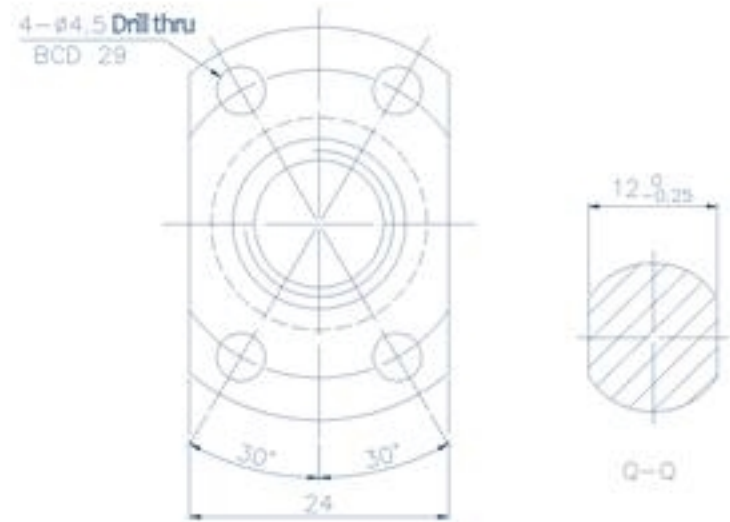

Stroke	Model No	L1	L2	L3	Accuracy grade
50	ASF1202-110x180	110	125	180	C3, C5
100	ASF1202-160x230	160	175	230	C3, C5
150	ASF1202-210x280	210	225	280	C3, C5
200	ASF1202-260x330	260	275	330	C3, C5
250	ASF1202-310x380	310	325	380	C5
290	ASF1202-350x420	350	365	420	C5
345	ASF1202-405x475	405	420	475	C5

Miniature Ball screw

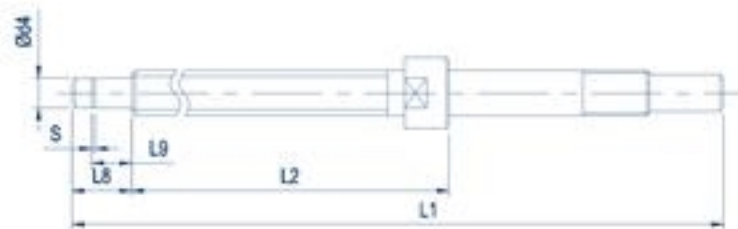
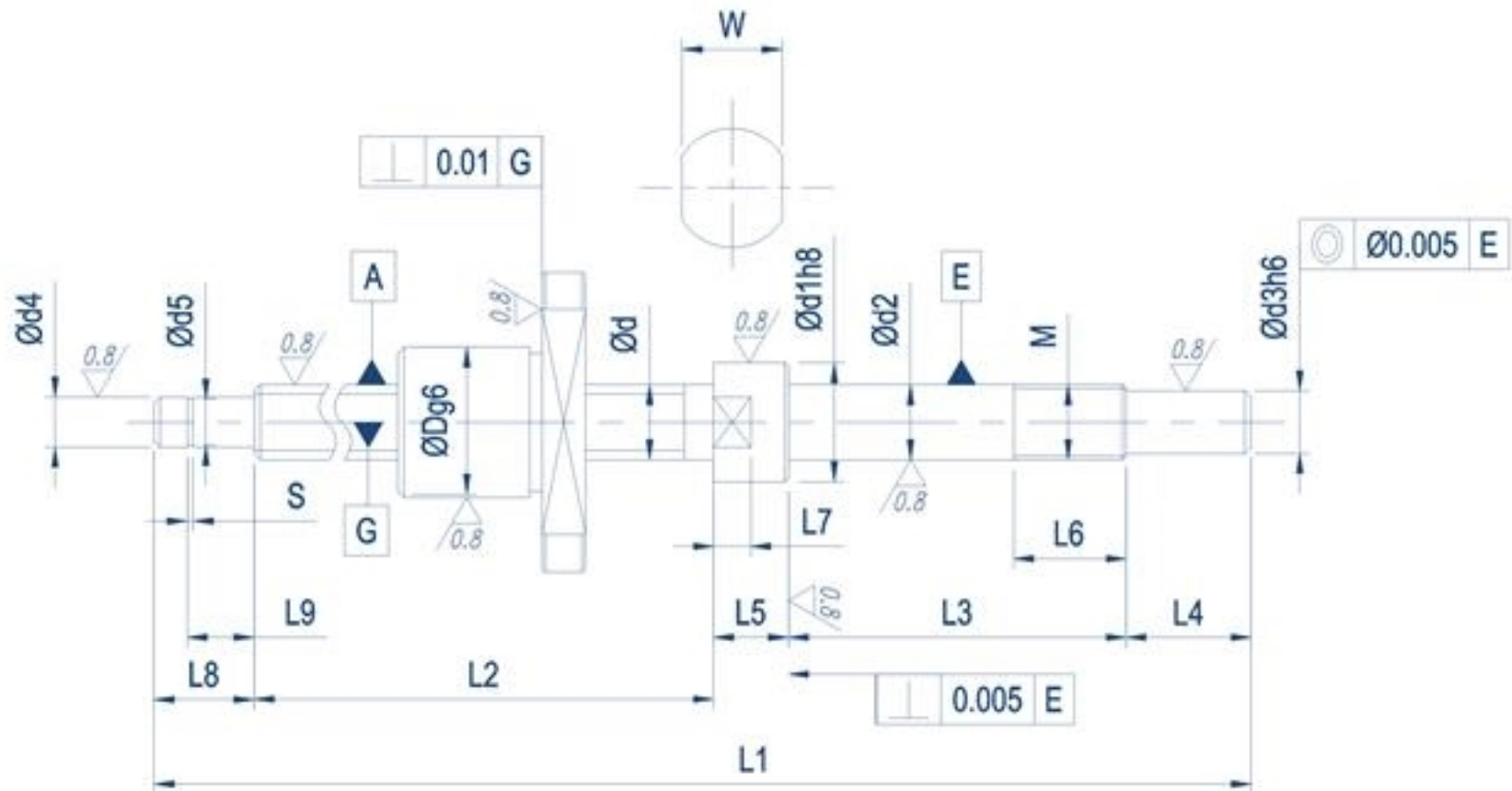

A Type

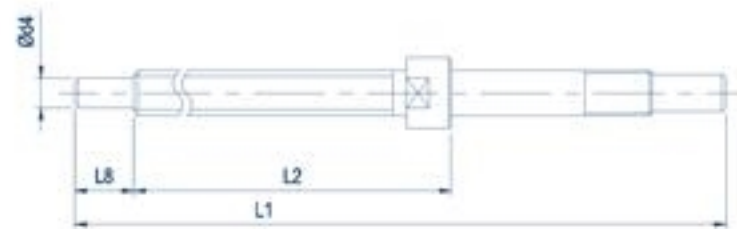

B Type

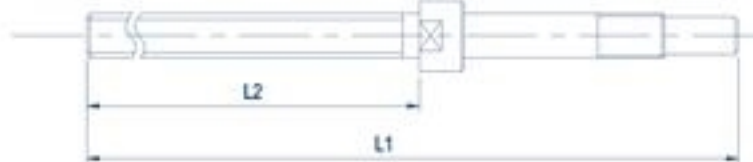

C Type

d	Fixed End A type B type C type											Support end							
												A type							
	B type			/															
	d1	L5	L7	W	d2	L3	M	L6	d3	L4	d4	L8	d5	S	L9				
4	6	⁰ / _{-0.018}	6	2.5	5	4	^{-0.004} / _{-0.012}	18	M4x0.5	6.5	3	⁰ / _{-0.006}	5	3	^{-0.002} / _{-0.010}	7	2.7	0.5	4.35
6	8	⁰ / _{-0.022}	7	3	7	5	^{-0.004} / _{-0.012}	19	M5x0.5	6.5	4	⁰ / _{-0.008}	6	4	^{-0.002} / _{-0.012}	8	3.7	0.5	5.35
8	9.5	⁰ / _{-0.022}	7	3	8	6	^{-0.005} / _{-0.014}	22.5	M6x0.75	7	4.5	⁰ / _{-0.008}	7.5	6	^{-0.002} / _{-0.012}	9	5.7	0.8	6.8
10	11.5	⁰ / _{-0.027}	8	4	10	8	^{-0.005} / _{-0.014}	27	M8x1.0	9	6	⁰ / _{-0.008}	10	6	^{-0.002} / _{-0.012}	9	5.7	0.8	6.8
12	14	⁰ / _{-0.027}	10	5	12	10	^{-0.006} / _{-0.017}	30	M10x1.0	10	8	⁰ / _{-0.009}	15	8	^{-0.004} / _{-0.012}	10	7.6	0.9	7.9
14	15	⁰ / _{-0.027}	10	5	12	12	^{-0.006} / _{-0.017}	30	M12x1.0	10	10	⁰ / _{-0.009}	15	10	^{-0.004} / _{-0.012}	12	9.6	1.15	9.15
16	16	⁰ / _{-0.027}	10	5	12	12	^{-0.006} / _{-0.017}	30	M12x1.0	10	10	⁰ / _{-0.009}	15	10	^{-0.004} / _{-0.012}	12	9.6	1.15	9.15

Notes: Customized end machining is available upon request

Miniature Ball screw

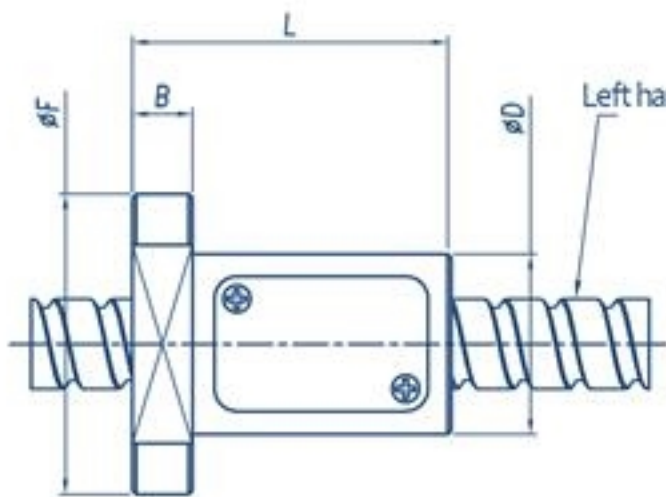

APF0804 APF0805 APF1208 APF1210

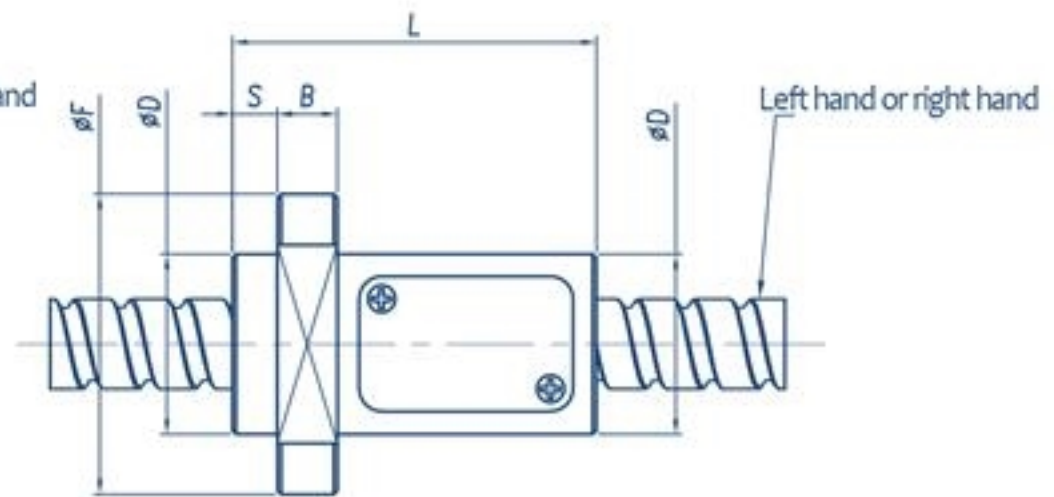

APF0808 APF1010

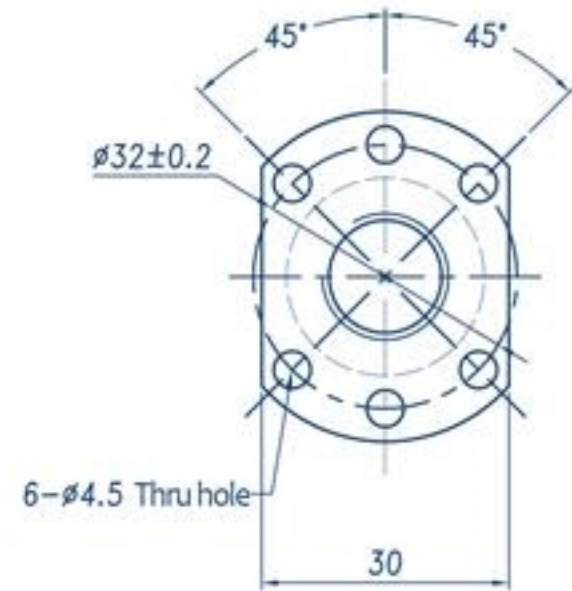
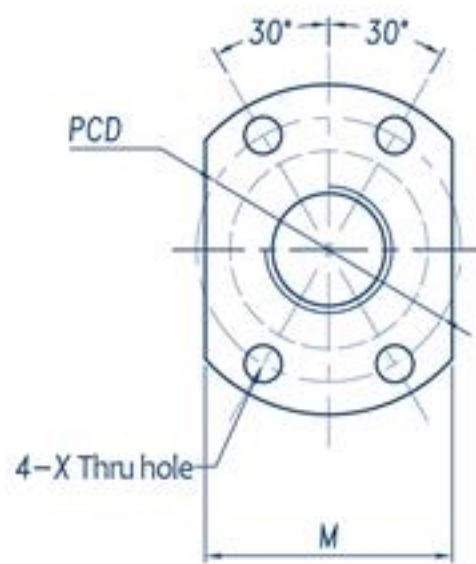
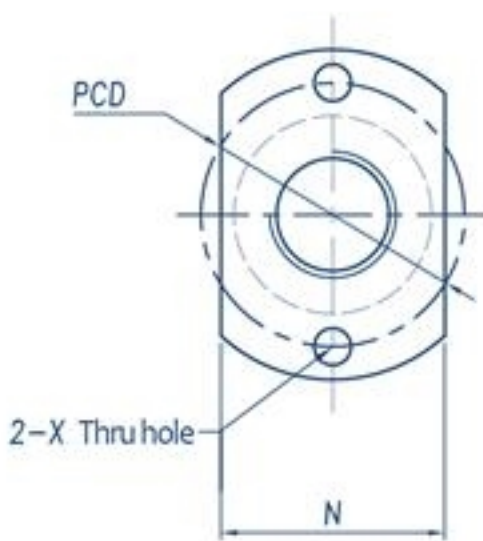

APF0808 APF1010

No	Model No	d	P	Da	No. of Circuit	loading(N)		Stiffness N/ μ m(K)	Nut size									
						Ca	Coa		D	F	L	S	PCD	B	No of mounting holes			X
															2孔 (N)	4孔 (M)	6孔	
1	APF0804	8	4	2.0	3.5	2300	3900	87	21	39	28	/	31	5	23	23	/	$\phi 4.5$
2	APF0805	8	5	1.588	2.5	1850	2960	85	18	31	28	/	25	4	20	20	/	$\phi 3.4$
3	APF0808	8	8	1.588	2.5	1700	3400	85	18	31	30	6	25	4	/	20	/	$\phi 3.4$
4	APF1010	10	10	2.0	2.5	2470	4600	92	23	40	36	6	32	6	/	25	/	$\phi 4.5$
5	APF1208	12	8	2.381	2.5	2840	5190	210	24	40	42	/	32	10	/	/	30	$\phi 4.5$
6	APF1210	12	10	2.5	2.8	6420	12870	190	24	40	48.5	/	32	10	/	/	30	$\phi 4.5$

Notes: Customized end machining is available upon request